

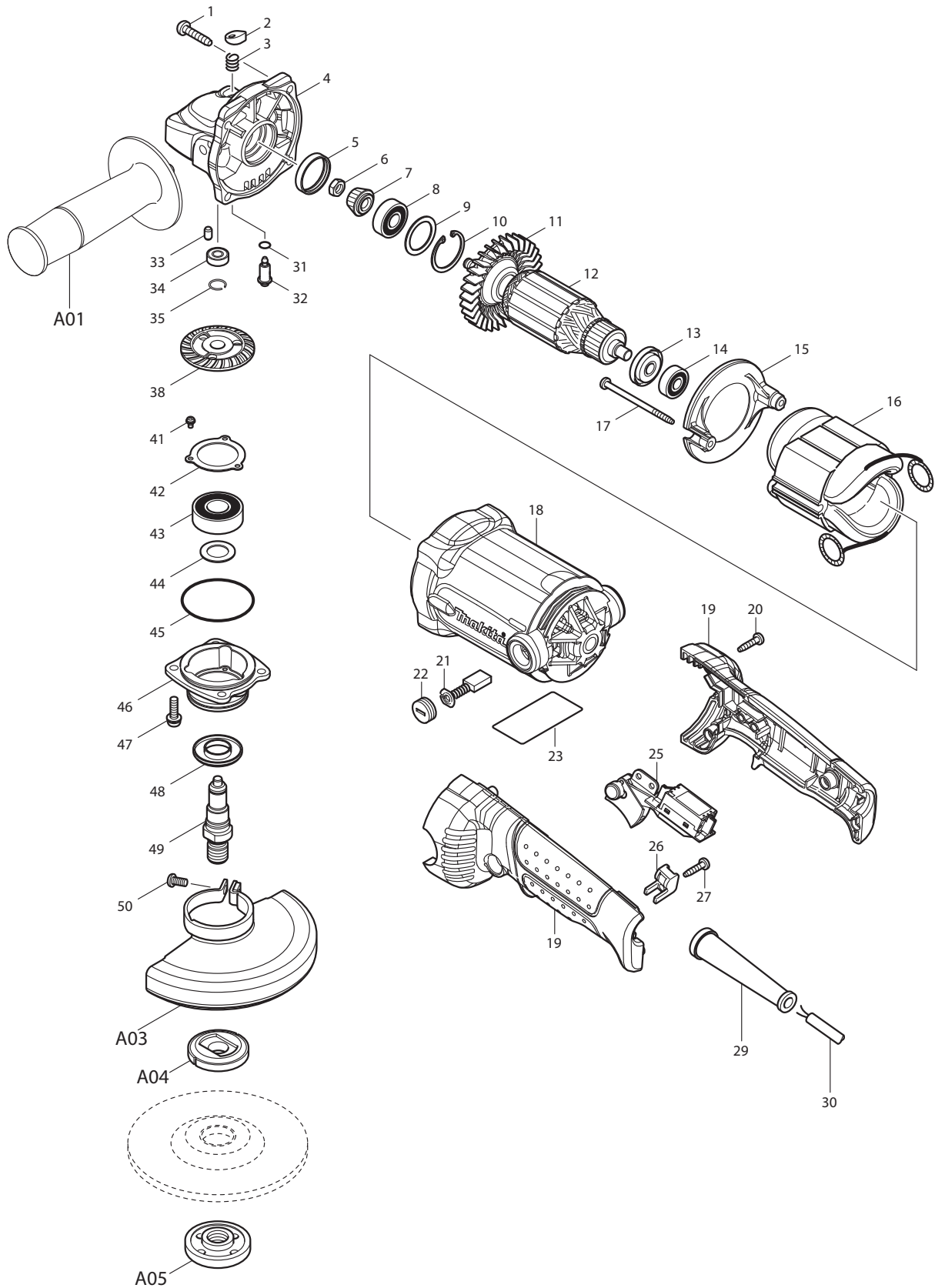

06 - 2010

GA5010

5" GRINDER, LOCK - ON



Item No	Type	Sub	Part No	Description	Qty	Unit
001	2		266459-3	TAPPING SCREW 5X25	4	PC.
002			417771-6	PIN CAP	1	PC.
003	2		234057-1	COMPRESSION SPRING 8	1	PC.
004			318158-4	GEAR HOUSING	1	PC.
005			262132-3	RUBBER RING 27	1	PC.
006			264010-3	HEX.NUT M7	1	PC.
007	1		227517-0	* SPIRAL BEVEL GEAR 13	1	PC.
	2		227520-1	* SPIRAL BEVEL GEAR 11	1	PC.
008	2		210059-1	BALL BEARING 6000DDW (Nylon)	1	PC.
009			267352-4	FLAT WASHER 22	1	PC.
010			962107-9	RETAINING RING (INT) R-30	1	PC.
011			240094-5	FAN 70	1	PC.
012			513701-6	ARMATURE ASS'Y 115V	1	PC.
		INC.		Item No. 11, 13, 14	1	PC.
013			681644-1	INSULATION WASHER	1	PC.
014			210005-4	BALL BEARING 608DDW	1	PC.
015			419961-7	BAFFLE PLATE	1	PC.
016	2		520055-4	* FIELD ASS'Y 115V (TYPE 2)	1	PC.
		INC.	654020-2	* RING TERMINAL	2	PC.
		INC.	654555-3	* CONNECTOR 34130	2	PC.
017			266340-8	TAPPING SCREW 4X65	2	PC.
018	2		158363-9	MOTOR HOUSING COMPLETE (TYPE 2)	1	PC.
		INC.	643708-9	BRUSH HOLDER 5-11	2	PC.
		INC.	810341-4	CAUTION LABEL	1	PC.
019			188291-4	HANDLE SET	1	SET
020			266326-2	TAPPING SCREW 4X18	4	PC.
021	2		194996-6	CARBON BRUSH CB-303 2PC/SET (W/ ORIGIN)	1	SET
022			643750-0	BRUSH HOLDER CAP	2	PC.
023			863595-2	NAME PLATE F/GA5010	1	PC.
025			651193-2	SWITCH TG933TR-1	1	PC.
026			687260-7	STRAIN RELIEF	1	PC.
027			266326-2	TAPPING SCREW 4X18	1	PC.
029			682505-8	CORD GUARD 10-90	1	PC.
030			664265-4	CORD WITH PLUG 2P-16-2.5M SJ	1	PC.
031			213977-2	O RING 7	1	PC.
032			256505-0	SHOULDER PIN 5	1	PC.
033			263002-9	RUBBER PIN 4	1	PC.
034			210006-2	BALL BEARING 696ZZ	1	PC.
035			233950-6	RING SPRING 11	1	PC.
038	1		227518-8	* SPIRAL BEVEL GEAR 34 A	1	PC.
	2		227521-9	* SPIRAL BEVEL GEAR 35 A	1	PC.
041			911003-8	PAN HEAD SCREW M3X6	3	PC.
042			285728-3	BEARING RETAINER 39	1	PC.
043			211228-7	BALL BEARING 6202DDW	1	PC.
044			253853-8	FLAT WASHER 15	1	PC.
045			213624-5	O RING 48	1	PC.
046	2		318300-7	* BEARING BOX	1	PC.
	3		318333-2	* BEARING BOX	1	PC.
047			265131-4	PAN HEAD SCREW M5X18	4	PC.
048			345464-4	LABYRINTH RING	1	PC.
049			324787-3	SPINDLE A	1	PC.
050	1		265103-9	* PAN HEAD SCREW M5X14 (FOR 125419-3)	1	PC.
	2		251391-4	* PAN HEAD SCREW M5X16 (F/135108-2,135650-3)	1	PC.
	3		265180-1	* PAN HEAD SCREW M5X16(F/123145-8)	1	PC.

Item No	Type	Sub	Part No	Description	Qty	Unit
100			652044-2	+BIND SCREW M3.5X5.0(F/Circuit Diagram)	4	PC.
101	1		654037-5	* INSULATED EYE TERMINAL FT1.25-M3 (F/Wiring Diagram)	4	PC.
	2		654117-7	* INSULATED TERMINAL (F/Wiring Diagram)	4	PC.
C01			848672-1	CARTON F/GA5010	1	PC.
ACCESSORIES			- See Catalogue or visit www.makita.ca for more accessories -			
A01	1		153504-2	GRIP 36 COMPLETE	1	PC.
	2		158237-4	GRIP 36 COMPLETE	1	PC.
	Opt.		194514-0	VIBRATION PROOF GRIP F/4" - 6", PKG	1	PC.
A02			782424-9	LOCK NUT WRENCH 28	1	PC.
A03	1		125419-3	* WHEEL COVER ASS'Y F/5" (INC. ITEM 50)	1	PC.
	2		135108-2	* TOOLLESS WHEEL COVER ASSY F/5" (INC. ITEM 50)	1	PC.
	3		135650-3	* TOOLLESS WHEEL COVER ASSY F/5" (INC. ITEM 50)	1	PC.
	4		123145-8	* TOOLLESS WHEEL COVER ASSY F/5" (INC. ITEM 50)	1	PC.
		INC.	213009-5	* O RING 4 (Added)	1	PC.
	Opt.1		122641-3	* CUT-OFF WHEEL GUARD F/5"	1	PC.
	Opt.2		122911-0	* CUT-OFF WHEEL GUARD F/5"	1	PC.
A04			224399-1	INNER FLANGE 45	1	PC.
A05			224568-4	LOCK NUT 5/8-45	1	PC.
A05			193048-0	SANDING LOCK NUT 5/8-48,PKGED	1	PC.
A06	1		741407-B	5" DEPRESSED CENTER WHEEL A24P	1	PC.
	2		A-95962-25	5" D.C.G.W WA36N 25/PK	1	SET
A07			D-20909	5" C.O.W. A30S	1	SET
			D-21004	5" C.O.W (7/8")	1	SET
A09			193794-5	* DUST COLLECTION WHEEL COVER 4-1/2", 5"	1	PC.
A10			743015-1	RUBBER PAD 115 F/5"	1	PC.
A11			194483-5	LOOP HANDLE SET	1	SET
		INC.	416256-9	LOOP HANDLE	1	PC.
		INC.	450189-8	SPACER A	1	PC.
		INC.	450190-3	SPACER B	1	PC.
		INC.	783204-6	HEX WRENCH 6	1	PC.
		INC.	922453-2	HEX. SOCKET SCREW M8X30	2	PC.
A12			194482-7	DUST COVER ATTACHMENT	1	PC.
A13	1		196846-1	* DUST COLLECTION COVER 5" DMND, TUCKPOINT BLADE	1	PC.
	2		196845-3	* DUST COLLECTION COVER 5" DMND, TUCKPOINT BLADE	1	PC.
A14			-----	4-1/2" - 5" DIAMOND TUCKPOINT BLADES		

SERVICE CHANGES

1. Changes on Filed Assy etc.

(TI#Z12397)

Item No.	Description	Type 1	Type 2
16	Field Ass'Y 115V	525766-6	520055-4
	INC. Ring Terminal	654020-2	
	INC. Connector P-1.25 > 34130	654501-6	654555-3
101	Insulated Term. FK1.25-3M >Insulating Terminal	654037-5	654117-7

See Technical Information #Z12397 for Wiring Change Diagram

2. Changes on Sprial Bevels

(TI#B3256)

Item No.	Description	Type1	Type2
7	Spiral Bevel Gear 13 > 11	227517-0	227520-1
38	Spiral Bevel Gear 34 A > 35 A	227518-8	227521-9

All parts above are interchangeable as a set

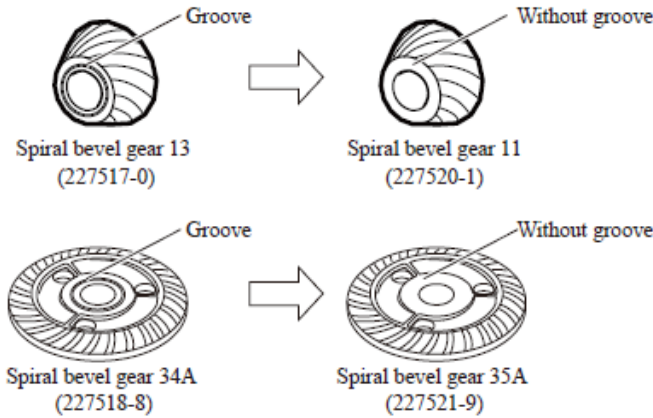

3. Changes on Wheel Cover Assembly & Bearing

(T/I# 80667, 79257)

(T/I# A4621, B3256)

Item No.	Description	Type1	Type2	Type3
46	Bearing Box	318159-2	318300-7 (Single notch)	318333-2 (Three notches)
50	Pan Head Screw M5X16	265103-9	251391-4	265180-1
A03	Wheel Cover Ass'y >Toolless Wheel Cover A125 Ass'y	125419-3	135108-2 (H:42mm) Or 135650-3 (H:46 mm)	123145-8
	INC. O ring 4	-----		213009-5
A09	Dust Collecting Wheel Guard	193794-5		196845-3
A13	Dust Collection Cover 5" Dmnd, Tuckpoint Blade	196846-1		
A15	Cut-Off Wheel Guard F/5"	122641-3		122911-0

Type 2 (single notche) and Type 3 (three notches) are completely interchangeable as a set.

GA5010 for Canada
GA5010Z for Canada, USA

