

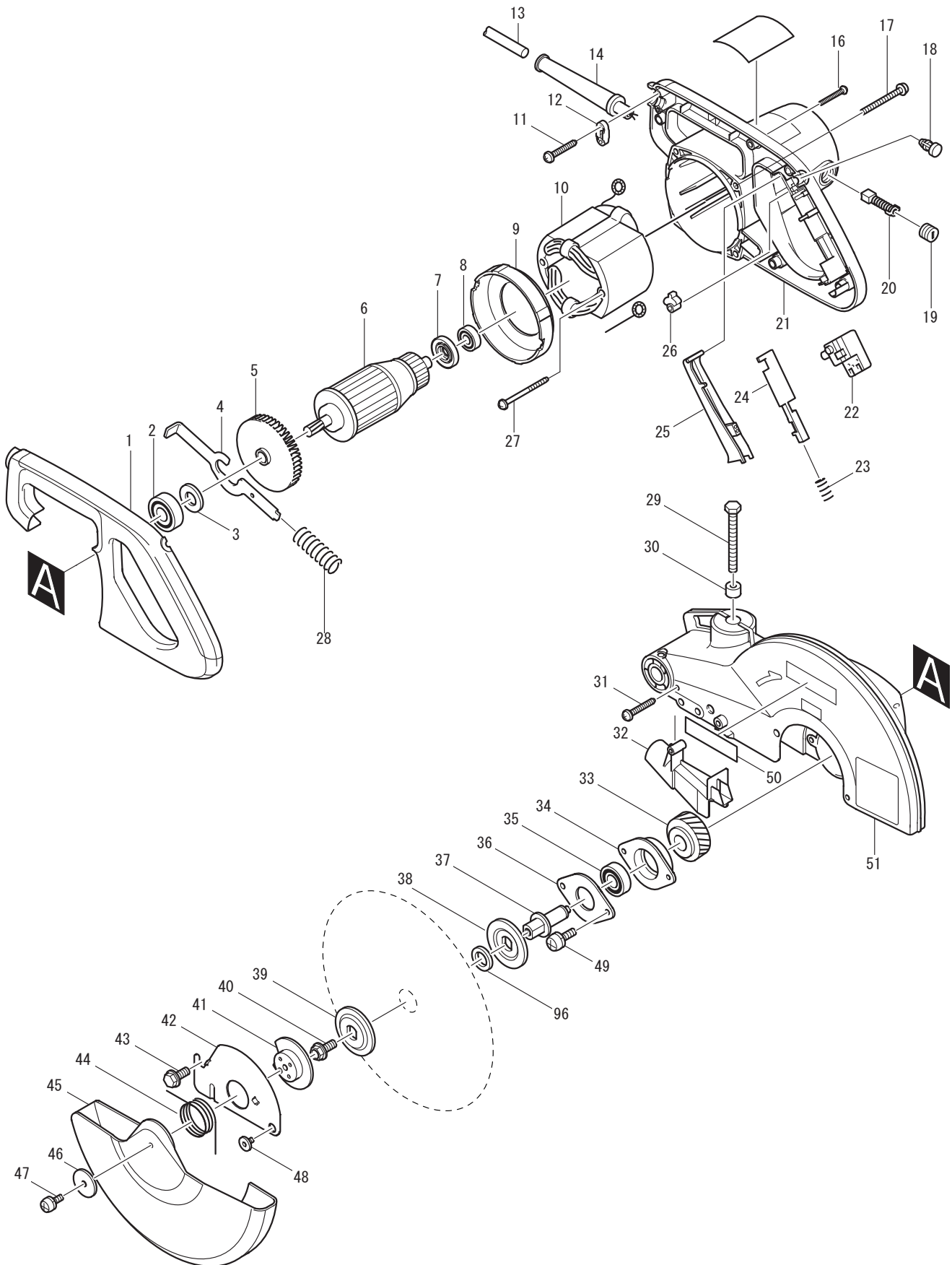

03 - 2010
LS1040
10" COMPOUND MITRE SAW
With BRAKE

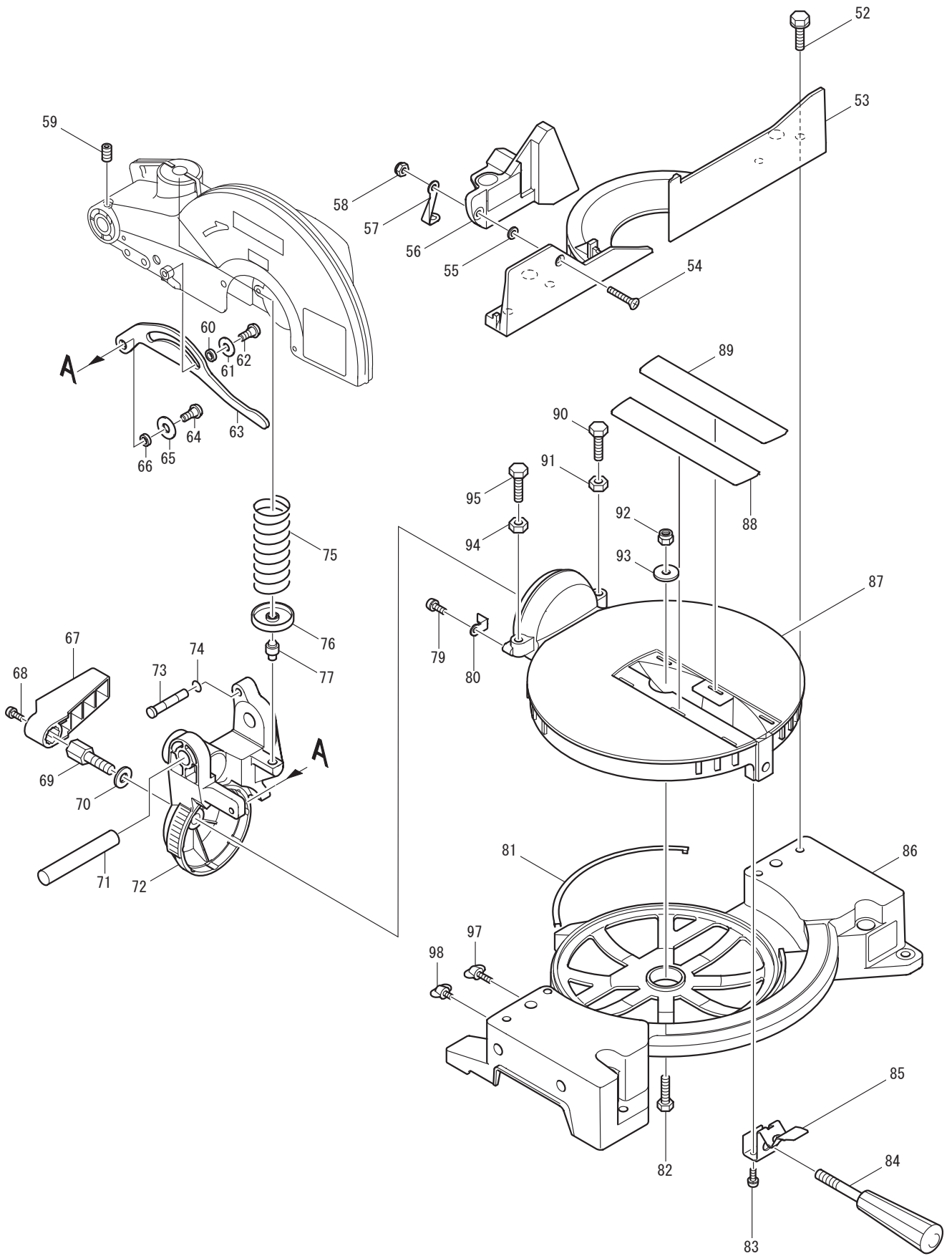



Item No	Type	Ref	Part No	Description	Qty	Unit
1			416004-6	HANDLE COVER	1	PC.
2			211206-7	BALL BEARING 6202LLB	1	PC.
3	2		267280-3	FLAT WASHER 15 - Ø19mm (7/8")	1	PC.
4			343641-2	SHAFT LOCK	1	PC.
5			241909-9	FAN 80	1	PC.
6			516716-2	ARMATURE ASS'Y 115V	1	PC.
		INC.		Item No. 2,3,5,7,8		
7			681640-9	INSULATION WASHER	1	PC.
8			211061-7	BALL BEARING 6000LLB	1	PC.
9	1		416002-0	* BAFFLE PLATE	1	PC.
	2		416442-2	* BAFFLE PLATE	1	PC.
10	2		526066-7	* FIELD ASS'Y 115V	1	PC.
	2	INC.	654020-2	* RING TERMINAL	1	PC.
	2	INC.	654502-4	* CONNECTOR P-2	1	PC.
11			265995-6	TAPPING SCREW 4X18	2	PC.
12	2		687124-5	STRAIN RELIEF	1	PC.
13			664463-0	CORD W/PLUG 2P-14-2.5M, SJ	1	PC.
14			682505-8	CORD GUARD 10-90	1	PC.
15			851559-8	NAME PLATE LS1040	1	PC.
16			265995-6	TAPPING SCREW 4X18	5	PC.
17			911383-2	PAN HEAD SCREW M6X60	4	PC.
18			411478-6	SWITCH BUTTON	1	PC.
19			643650-4	BRUSH HOLDER CAP 6.5-13.5	2	PC.
20	2		194986-9	CARBON BRUSH CB-154 2PC/SET W/ ORIGIN	1	SET
21	2		153793-9	* MOTOR HOUSING COMPLETE	1	PC.
	2	INC.	817881-3	* CAUTION LABEL	1	PC.
	2	INC.	643653-8	* BRUSH HOLDER 6.5-13.5	2	PC.
22			651923-1	SWITCH TG70B	1	PC.
23			231457-6	COMPRESSION SPRING 3	1	PC.
24			416000-4	LOCK OFF LEVER	1	PC.
25			415999-0	SWITCH LEVER	1	PC.
26			414546-4	CAM	1	PC.
27			266029-8	TAPPING SCREW 5X65	2	PC.
28			231297-2	COMPRESSION SPRING 9	1	PC.
29			251667-9	HEX. BOLT M8X75	1	PC.
30			262511-5	RUBBER SLEEVE 6	1	PC.
31			265995-6	TAPPING SCREW 4X18	1	PC.
32	2		453695-2	GUIDE COVER	1	PC.
33			226465-0	HELICAL GEAR 42	1	PC.
34			316821-3	BEARING BOX	1	PC.
35			211256-2	BALL BEARING 6203LLB	1	PC.
36			285685-5	BEARING RETAINER 64	1	PC.
37			322865-3	SPINDLE	1	PC.
38			224333-1	FLANGE 53	1	PC.
39			224333-1	FLANGE 53	1	PC.
40			265355-2	HEX. FLANGE HEAD BOLT M8X20	1	PC.
41			343639-9	CENTER PLATE	1	PC.
42			344380-7	CENTER COVER	1	PC.
43			265324-3	HEX. FLANGE HEAD BOLT M8X12	1	PC.
44			231593-8	TORSION SPRING 36	1	PC.
45			416003-8	SAFETY COVER	1	PC.
46			267136-0	FLAT WASHER 5	1	PC.

Item No	Type	Ref	Part No	Description	Qty	Unit
47	1		911213-7	PAN HEAD SCREW M5X12	1	PC.
	2		922211-6	HEX SOCKET HEAD SCREW M5X12	1	PC.
48			265985-9	HEX.SOCKET HEAD BOLT M6	1	PC.
49			911223-4	PAN HEAD SCREW M5X16	2	PC.
50			819064-1	* MAKITA MARK (OLD)	1	PC.
51	4		188325-3	* BLADE CASE SET	1	SET
	4	INC.	816847-0	* OPERATIONAL INDICATION LABEL	1	PC.
	4	INC.	817874-0	* CAUTION LABEL	1	PC.
	4	INC.	263005-3	* RUBBER PIN 6	1	PC.
	4	INC.	819214-8	* MAKITA LOGO LABEL (Add)(Old)	1	PC.
	5		140649-5	* BLADE CASE COM	1	SET
	5	INC.	816847-0	* OPERATIONAL INDICATION LABEL	1	PC.
	5	INC.	891310-4	* CAUTION LABEL	1	PC.
	5	INC.	263005-3	* RUBBER PIN 6	1	PC.
52	2		265488-3	HEX. BOLT M8X30	4	PC.
53	2		318847-1	GUIDE RULE	1	PC.
54			912342-9	COUNTERSUNK HEAD SCREW M6X25	1	PC.
55			253715-0	FLAT WASHER 6	1	PC.
56			150663-3	SUB FENCE COMPLETE (Silver -->Yellowish Gray)	1	PC.
56		INC.	810858-7	CAUTION LABEL	1	PC.
57			344476-4	SUB FENCE PLATE	1	PC.
58			252014-7	HEX. LOCK NUT M6-10	1	PC.
59			251961-9	H.S.SET SCREW(FLAT POINT)M6X10	1	PC.
60			257162-7	WASHER 7	1	PC.
61			253823-7	FLAT WASHER 7	1	PC.
62			265984-1	HEX.SOCKET BUTTON HEAD BOLT M6	1	PC.
63			344377-6	LINK PLATE	1	PC.
64			265984-1	HEX.SOCKET BUTTON HEAD BOLT M6	1	PC.
65			253823-7	FLAT WASHER 7	1	PC.
66			257162-7	WASHER 7	1	PC.
67			416006-2	LEVER 100	1	PC.
68			911113-1	PAN HEAD SCREW M4X10	1	PC.
69			265437-0	HEX. BOLT M10	1	PC.
70			253024-7	FLAT WASHER 10	1	PC.
71			256836-7	ROD 16	1	PC.
72	3		154463-3	* ARM COMPLETE	1	PC.
	3	INC.	816310-3	* SCALE LABEL	1	PC.
73			322317-4	STOPPER PIN	1	PC.
74			213021-5	O RING 5	1	PC.
75			233152-4	COMPRESSION SPRING 28	1	PC.
76	1		343638-1	* SPRING HOLDER	1	PC.
	2		344464-1	* SPRING HOLDER	1	PC.
77			256280-8	* PIN 8	1	PC.
78			257681-3	* SLEEVE 8 (Old)	1	PC.
79			911113-1	PAN HEAD SCREW M4X10	1	PC.
80			344385-7	POINTER	1	PC.
81			343799-7	SLIDE PLATE	3	PC.
82			921452-1	HEX. BOLT M8X30	1	PC.
83			911213-7	PAN HEAD SCREW M5X12	2	PC.
84			273495-2	GRIP 32	1	PC.
85			344381-5	KNOCK SPRING	1	PC.

Item No	Type	Ref	Part No	Description	Qty	Unit
86			150648-9	BASE COMPLETE (Silver --> Yellowish gray)	1	PC.
		INC.	816311-1	MITER SCALE PLATE	1	PC.
		INC.	817838-4	CAUTION LABEL	1	PC.
		INC.	817283-3	CAUTION LABEL	2	PC.
87			316824-7	TURN BASE (Silver --> Yellowish gray)	1	PC.
88			416001-2	KERF BOARD	1	PC.
89			416001-2	KERF BOARD	1	PC.
90			921452-1	HEX. BOLT M8X30	1	PC.
91			931402-8	HEX. NUT M8	1	PC.
92			252105-4	HEX. LOCK NUT M8-13	1	PC.
93	2		253762-1	FLAT WASHER 8	1	PC.
94			931402-8	HEX. NUT M8	1	PC.
95			921452-1	HEX. BOLT M8X30	1	PC.
100			687080-9	FIELD CLAMP	2	PC.
101			654098-5	RECEPTACLE	4	PC.
C01	2		879789-9	CARTON F/LS1040	1	PC.

ACCESSORIES

- See Catalogue or visit www.makita.ca for more accessories information -

A01			411478-6	SWITCH BUTTON	2	PC.
A02			762001-3	TRIANGULAR RULE	1	PC.
A03			782212-4	SOCKET WRENCH 13	1	PC.
A04	2		122852-0	DUST BAG ASS'Y	1	PC.
	2	INC.	410602-8	FASTENER	1	PC.
A05	1		122531-0	SUB PLATE ASS'Y	1	PC.
	1	INC.	252148-6	SQUARE NUT M8	1	PC.
	1	INC.	921431-9	HEX. BOLT M8X20	1	PC.
	2		193471-9	SUB PLATE ASS'Y (OLD# 122531-0)	1	PC.
	2	INC.	252148-6	SQUARE NUT M8	1	PC.
	2	INC.	921431-9	HEX. BOLT M8X20	1	PC.
A06			122536-0	WISE ASS'Y	1	PC.
		INC.	251370-2	+ PAN HEAD SCREW I5	1	PC.
		INC.	251887-5	SCREW M6X10	1	PC.
		INC.	253804-1	FLAT WASHER 6	1	PC.
		INC.	271286-5	KNOB 40	1	PC.
		INC.	316938-2	WISE ARM	1	PC.
		INC.	322313-2	WISE ROD	1	PC.
		INC.	343651-9	WISE PLATE	1	PC.
A07			192622-1	CROWN MOLDING STOPPER SET	1	PC.
A08			256812-1	EXTENSION ROD	2	PC.
A09			192621-3	HOLDER SET (2PCS)	1	PC.
		INC.	251896-4	SCREW M5X20	2	PC.
A10			122472-0	SET PLATE ASSY	1	PC.
		INC.	251887-5	SCREW M6X10	1	PC.
A11			192713-8	FOOT ASSY	1	PC.
		INC.	265917-6	ADJUST BOLT M8X42	2	PC.
		INC.	251887-5	SCREW M6X10	1	PC.
A12			122536-0	VERTICAL VISE ASSY (YELLOWISH GRAY)	1	PC.

Item No	Type	Ref	Part No	Description	Qty	Unit
A13			122563-7	HORIZONTAL VISE ASSY	1	PC.
	INC.		253047-5	FLAT WASHER 6	1	PC.
	INC.		253744-3	FLAT WASHER 12	1	PC.
	INC.		271275-0	KNOB 45	1	PC.
	INC.		315891-9	VICE PLATE	1	PC.
	INC.		321490-7	RELEASE NUT R	1	PC.
	INC.		321491-5	RELEASE NUT L	1	PC.
	INC.		341911-3	PROTECTOR	2	PC.
	INC.		341912-1	NUT HOLDER	1	PC.
	INC.		342967-9	SET PLATE	1	PC.
	INC.		911216-1	P.H. SCREW M5X14	1	PC.
	INC.		911317-5	P.H. SCREW M6X14	1	PC.
A14			194061-1	BENCHTOP MITER SAW STAND (Parts Breakdown Available)	1	PC.
A15			721434-1	10" C.T.SAW BLADE 32T	1	PC.

SERVICE CHANGES

1. Changes on Baffle Plate, Field Assy and Motor Housing Complete.

(T/I# Z5642)

Item No.	Description	Type 1	Type 2	Type 3
9	Baffle Plate	416002-0		416442-2
10	Field Assy 115V	596136-6 (or 636136-5)		526066-7
21	Motor Housing Com	159916-7		153793-9
	Brush holder (component of Item 21)	643660-1 □		643653-8
98	Screw M6X20	-----		265708-5

Item No. 9 - 21 are completely interchangeable as a set.

Item No. 98 is interchangeable as itself.

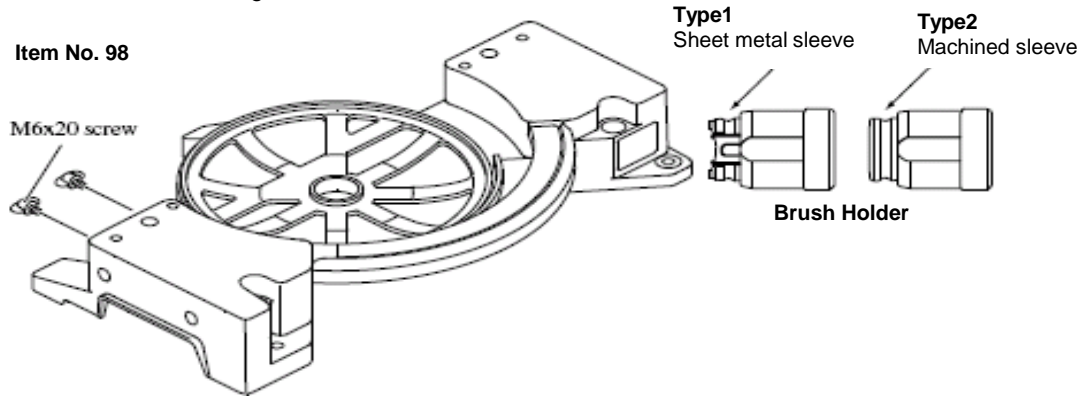

**See Wiring Change on T/I# Z5642

2. Changes on Blade Case Complete / Set

Item No.	Description	Type 1	Type 2	Type 3	Type 4	Type 5
51	Blade Case	151461-8 (Complete)		188325-3 (Set)		140649-5 (Complete)
	color of blade case	Silver		Yellowish gray		
	Makita Logo Label (component of Item 51)	-----		819214-8		-----
	Caution /Indication label	817667-5 (caution label)			816847-0 (indication label)	
	Caution	817874-0				891310-4
50	Makita Mark	819064-1		-----		

SERVICE CHANGES

3. Changes on Arm Complete

Item No.	Description	Type 1	Type 2	Type 3
72	Arm Complete		150664-1	154463-3
	color of Arm complete	Silver	Yellowish gray	

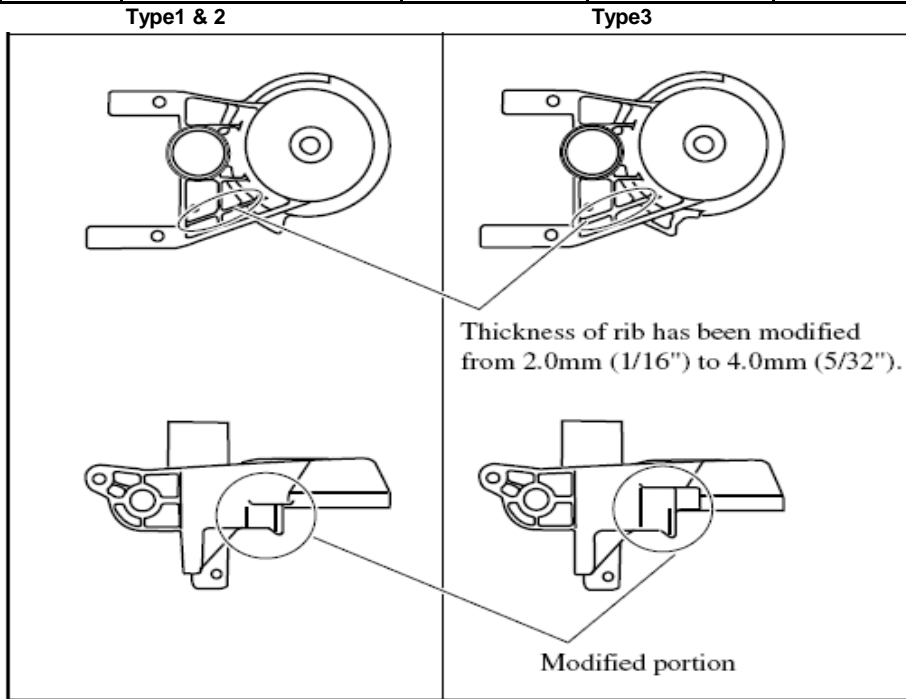

4. Changes on Style of Spring Holder and Pin 8

Item No.	Description	Type 1	Type 2
76	Spring Holder	343638-1	344464-1
77	Pin 8	256199-1	256280-8
78	Sleeve 8	257681-3	-----

Above parts are completely interchangeable as a set.

