



 **VEGA**
The Future of Fastener Driving Tools

TABLE OF CONTENTS

Company Overview	2
Product Knowledge & Resources	4
Impactech®	7
Driver Bits	13
+ Phillips.....	14
+ Phillips Tamper	16
□ Square.....	17
★ TORX®	18
★ TORX® Tamper.....	20
★ TORX® Align.....	21
★ TORXplus®, ★ TORXplus® Tamper	22
⬡ Hex	24
⬡ Hex Tamper, ⬡ Hex Ball.....	27
◐ Slotted.....	29
✳ POZIDRIV®	30
+ MORTORQ®, + MORTORQ® Super.....	31
+ TORQ-SET®	32
▲ TRI-WING®	33
★ Double Square, ★ Triple Square	34
● Spanner, ● Clutch, ◐ HTS.....	35
+ Phillips Square-Driv ACR®, + Phillips Square Combo	36
+ Frearson.....	36
Stainless Steel Bits.....	37
Titanium Nitride Bits.....	38
Diamond Tipped Bits	39
Bit Holders.....	40
Nutsetters	43
Adapters/ Extensions.....	46
Bit Sets.....	48
Impact Sockets	54
Screwdrivers.....	72
T-Handles	75
L-Keys	78
Flag Drivers.....	81
Merchandising	83

COMPANY OVERVIEW

HISTORY

For over 25 years Vega has been producing industry leading driver bits and other fastener driving tools. Vega identified a need in contractor supply and industrial distribution for a complete line of fastener driving tools that matched the high quality and performance of existing fastener driving tools in North America, but at significant savings for distributors selling to professional end users and assembly oriented manufacturing companies. Over the past 3 decades Vega has continued to grow our product line to now well over 2,000 SKU's.

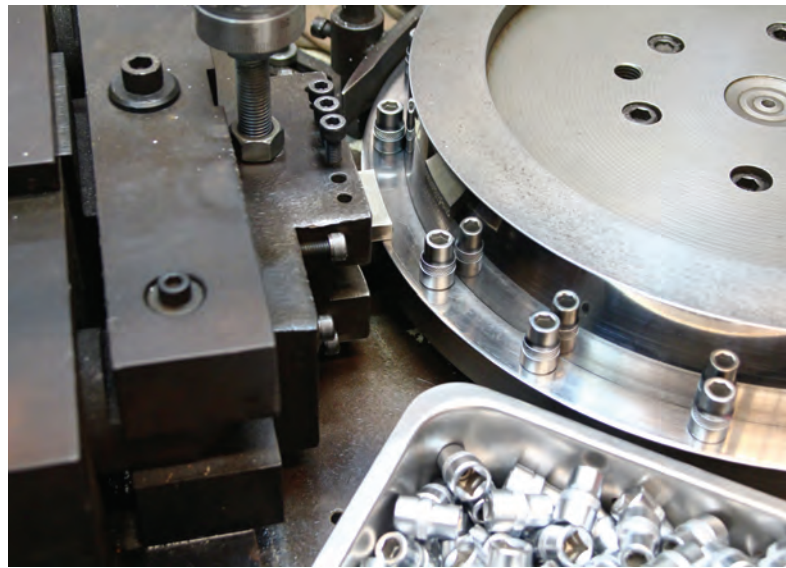

INDUSTRY & MARKET EXPERIENCE

Our distributors have come to depend on Vega's ability to provide better performance and quality than our competitors at costs that drive improved margins for our distributors.

Vega is a member of STAFDA, ISA and NetPlus and we strive to understand our customer's business and needs. We have a nationwide sales organization that is committed to supporting customer initiatives by driving execution and training at the branch level.

By working with Vega, you have chosen a supplier that is considered a global expert in fastener driving tools ... and ONLY fastener driving tools! We look forward to being able to provide you with a superior experience with Vega products.



EXPERTS IN MANUFACTURING

CAPABILITIES & PROCESS

We design and manufacture all of our tools in our company owned ISO 9001:2008 facilities. We do not source or contract out production to other manufacturers. This gives us complete control in design and quality. The manufacturing processes used in the production of our fastener driving tools are regarded to be some of the best in the world today:

- Consistent dimensional accuracy through CNC machining
- State-of-the-art proprietary heat treatment processes
- Superior quality materials including S2 modified steel
- Diligent testing and quality control

These features result in the most proven durable fastener driving tools on the market. Reduced cam-out and extended service life are the benefits consistently experienced by our end users.

Our products meet ANSI or ISO specifications where applicable.

MACHINING ADVANTAGES

Machining is the most precise manufacturing method for managing tolerances, resulting in less bit wear and cam-out due to achieving a precise fastener fit. Forging does not allow for the sharp corners and angles necessary for the most precise fastener fit.

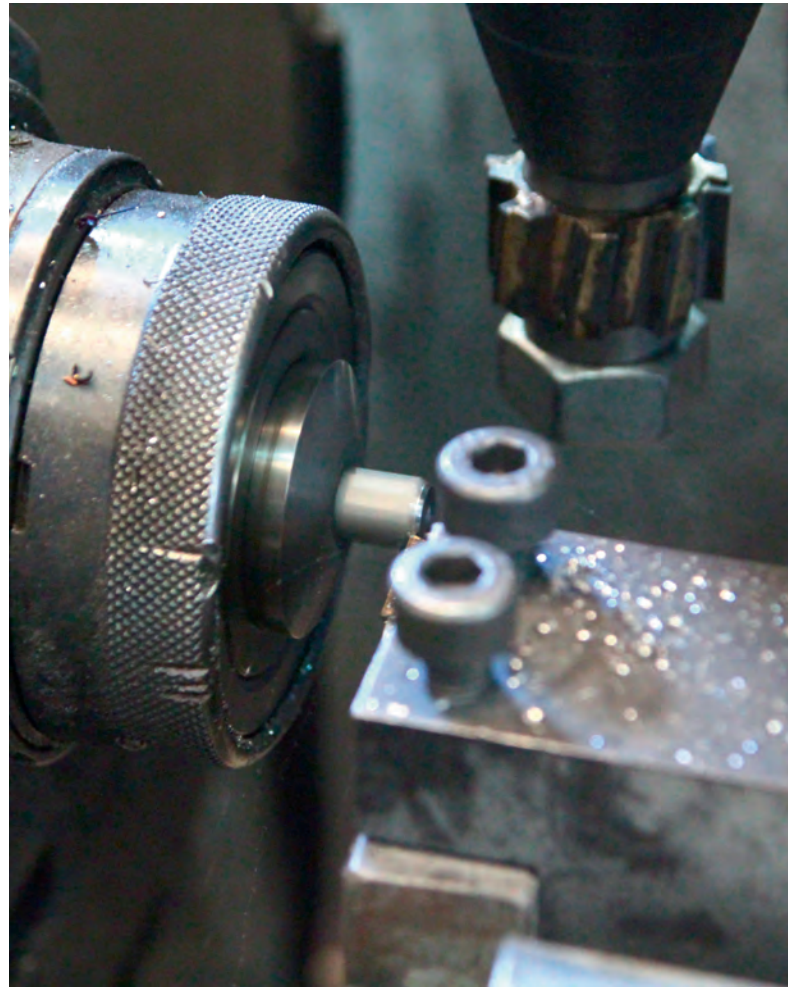

LICENSES

To meet the requirements of our distributors' end customers, Vega offers driver bits that are licensed to use these well know trademarks: TORX®, TORXPLUS®, TORXALIGN®, TORX® TAMPER, TORQ-SET®, MORTORQ®, MORTORQ® SUPER, POZIDRIV®, TRI-WING®, PHILLIPS SQUARE-DRIV®, and ACR®. All licensed bits are manufactured in strict compliance to the dimensional specifications of the licensing companies.

TORX®, TORXPLUS®, TORXALIGN® and TORX® TAMPER are registered trademarks of Acument Global Technologies.

TORQ-SET®, MORTORQ®, MORTORQ® SUPER, POZIDRIV®, TRI-WING®, PHILLIPS SQUARE-DRIV®, and ACR® are registered trademark of the Phillips Screw Co.

PRODUCT KNOWLEDGE AND RESOURCES

At Vega we're committed to being experts in fastener driving tools. The following information is to help you gain an understanding of some of features and applications for fastening tools. For additional questions or information contact our team of tool experts. We're here to help.

APPLICATION GUIDE

This guide provides an overview of some of the main industries using fastener driving tools and the most common tip configurations that they use.

SELECTING THE PROPER HARDNESS LEVEL FOR BITS

Choosing the proper hardness level for fastener driving tools is important to achieve the desired performance between the fastener and bit. Different applications, operators and power tools require different hardness levels. Vega offers a choice of two hardness levels in many of our bits, Standard and Extra Hard (X). Extra Hard bits are designated by adding an 'X' onto the end of the part number. Also look for the **X-HARD** icon throughout the catalog which highlights categories where extra hard bits are available.



APPLICATION GUIDE	PHILLIPS	SQUARE	SLOTTED	TORX	TORX TAMPER	TORX ALIGN	HEX	HEX TAMPER	POZIDRIV	TORQ-SET	TRI-WING	SPANNER	MORTORQ	MORTORQ Super	FREARSON
APPLIANCE	•	•	•	•		•			•						
AUTOMOTIVE	•		•	•		•	•		•					•	
AVIATION	•		•							•	•		•		•
CABINETY		•													•
CONSTRUCTION	•		•						•						
CONTROL PANELS							•					•			
DECKING	•	•	•						•						
DRYWALL	•	•													
ELECTRONICS	•		•	•	•	•	•			•	•				
FURNITURE	•	•	•				•								
HOBBY	•		•				•								•
HVAC	•	•	•				•								
MACHINE TOOLS/ METAL							•	•							
MANUFACTURED HOUSING		•													
MARINE	•		•												•
RECREATION	•	•	•				•	•							•
SECURITY	•				•		•	•		•	•	•			
SUBFLOOR	•	•													



The proper hardness level depends on the failure mode. If the bit breaks or shatters, select a bit with less hardness. If the failure mode is wear, select a harder bit. In general, high torque applications require lower hardness levels to withstand twisting and resist breakage. Extra Hard bits are mainly used in low torque applications, particularly with hardened screws.

The standard hardness level should be selected unless a specific application suggests using an increased hardness level. Contact your Vega representative for specific recommendations.

MATERIAL & FINISH KNOWLEDGE

S2 Modified Steel – All Vega bits are made from shock resistant S2 modified steel and have a Rockwell hardness of between 58-62 HRC. S2 Modified steel is the most durable material for the performance required by our professional end users.



Stainless Steel – Ideal for environments where corrosion and rust are severe. The high performance Stainless Steel used by Vega provides a superior mix of strength and corrosion resistance.



Diamond Tip – The diamond grit is embedded in the steel substrate and improves screw engagement reducing the risk of damage to the screw recess. This extra hard diamond coating wears less and grips better than a Titanium coating.



Titanium Nitride – These bits have a rough surface creating millions of micro gripping points. The Titanium coating provides an extra hard surface over the gripping points to protect them during use. The increase in roughness grips the entire recess of the screw and reduces cam out.



FASTENER DRIVING TOOL TERMINOLOGY

ACR® – ACR stands for anti-camout recess. There are ribs on the driver bit that engage the fastener recess to reduce stripping, provide increased torque, enhance off-angle drivability, and offer a stick fit that makes screw driving easier.

Shank – The shank is the hex end of a bit grasped by the chuck of a tool.

Torsion Zone – In a true torsion bit this is the reduced diameter section of the shank between the hex body and tip. This area absorbs torque during impact extending the life of the bit.

Lobular Design – Is a radius cold formed on the inside walls of a nutsetter. This design reduces stripping damage by driving the hex head fastener on the sides instead of the corners.

Finder Sleeve – A sleeve typically used on slotted bits that slides over the slotted fastener preventing the bit from slipping out of the fastener while driving it.

Ball Lock – This design uses a ball and spring tension method to secure sockets to an extension or adapter. Tools can typically be removed by hand allowing for quick changes.

Pin Lock – This design uses a pin and spring tension method to secure sockets to an extension or adapter. It is a more secure retention method than a ball lock and is commonly used in production applications.

C-Ring – A retention method used in bit holders where a ring in the bit holder locks around corresponding grooves in an insert bit to firmly hold it in place.

Quick-Release – Mechanism commonly used in bit holders and extensions where a retractable sleeve that when extended quickly releases the bit avoiding the need for force or pressure to remove it.

Bull Nose – A style of bit where the tip of the bit is a larger diameter than the hex shank body.

ACR® is a registered trademark of the Phillips Screw Co



- Full line of bits and accessories specifically designed for use with power impact tools
- Tested to outperform all leading brands in life cycle and tip failure testing
- Patented spiral torsion zone absorbs impact resulting in longer bit life
- Precision engineered tips are manufactured with proprietary CNC machining process
- Made from S2 modified impact resistant steel
- Variety of packaging and merchandising options to suit a full range of distributor needs

IMPACTECH™



Impactech™ is a complete product range designed specifically for the professional users of power impact tools



- Patented spiral torsion zone absorbs impact resulting in longer bit life
- Precision engineered tips are manufactured with proprietary CNC machining process
- Made from S2 Modified impact resistant steel

AVERAGE DEGREE OF ROTATION AT TIP FAILURE

Tested to outperform all leading brands in life cycle and tip failure testing



TEST RESULTS:

Average Degree of Rotation at Tip Failure
(2 inch #2 Phillips Bits)

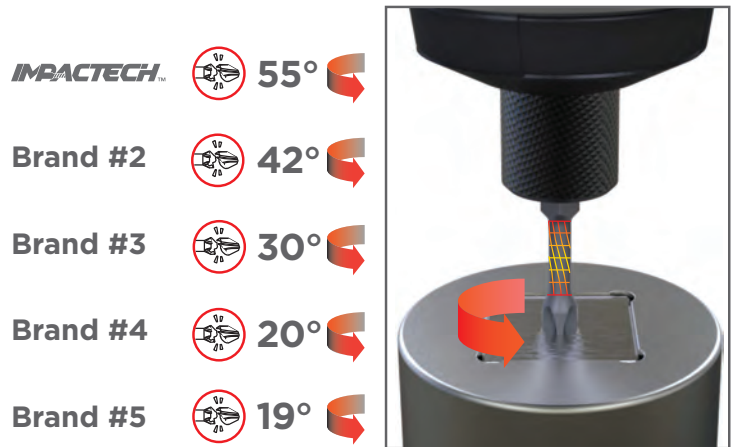

The more a bit flexes during rotation, the more it absorbs impact



NEW! PHILLIPS INSERT BITS

PART NUMBER	TIP SIZE	LENGTH	PIECE COUNT	PACKAGING
P125P1A	#1	1"	1	Bulk
P125P1A-C2	#1	1"	2	Carded
P125P1A-C5	#1	1"	5	Carded
P125P2A	#2	1"	1	Bulk
P125P2A-C2	#2	1"	2	Carded
P125P2A-C5	#2	1"	5	Carded
P125P3A	#3	1"	1	Bulk
P125P3A-C2	#3	1"	2	Carded
P125P3A-C5	#3	1"	5	Carded



NEW! SQUARE INSERT BITS

PART NUMBER	TIP SIZE	LENGTH	PIECE COUNT	PACKAGING
P125R1A	#1	1"	1	Bulk
P125R1A-C2	#1	1"	2	Carded
P125R1A-C5	#1	1"	5	Carded
P125R2A	#2	1"	1	Bulk
P125R2A-C2	#2	1"	2	Carded
P125R2A-C5	#2	1"	5	Carded
P125R3A	#3	1"	1	Bulk
P125R3A-C2	#3	1"	2	Carded



NEW! PHILLIPS POWER BITS

PART NUMBER	TIP SIZE	LENGTH	PIECE COUNT	PACKAGING
P150P1A	#1	2"	1	Bulk
P150P1A-C1	#1	2"	1	Carded
P150P2A	#2	2"	1	Bulk
P150P2A-C2	#2	2"	2	Carded
P150P2A-C5	#2	2"	5	Carded
P150P3A	#3	2"	1	Bulk
P150P3A-C1	#3	2"	1	Carded
P170P1A	#1	2-3/4"	1	Bulk
P170P2A	#2	2-3/4"	1	Bulk
P170P3A	#3	2-3/4"	1	Bulk
P190P1A	#1	3-1/2"	1	Bulk
P190P2A	#2	3-1/2"	1	Bulk
P190P2A-C1	#2	3-1/2"	1	Carded
P190P2A-C5	#2	3-1/2"	5	Carded
P190P3A	#3	3-1/2"	1	Bulk
P190P3A-C1	#3	3-1/2"	1	Carded
P1150P1A	#1	6"	1	Bulk
P1150P2A	#2	6"	1	Bulk
P1150P2A-C1	#2	6"	1	Carded
P1150P3A	#3	6"	1	Bulk



NEW! SQUARE POWER BITS

PART NUMBER	TIP SIZE	LENGTH	PIECE COUNT	PACKAGING
P150R1A	#1	2"	1	Bulk
P150R1A-C1	#1	2"	1	Carded
P150R2A	#2	2"	1	Bulk
P150R2A-C1	#2	2"	1	Carded
P150R2A-C5	#2	2"	5	Carded
P150R3A	#3	2"	1	Bulk
P150R3A-C1	#3	2"	1	Carded
P170R1A	#1	2-3/4"	1	Bulk
P170R2A	#2	2-3/4"	1	Bulk
P170R3A	#3	2-3/4"	1	Bulk
P190R1A	#1	3-1/2"	1	Bulk
P190R2A	#2	3-1/2"	1	Bulk
P190R2A-C1	#2	3-1/2"	1	Carded
P190R3A	#3	3-1/2"	1	Bulk
P1150R1A	#1	6"	1	Bulk
P1150R2A	#2	6"	1	Bulk
P1150R2A-C1	#2	6"	1	Carded
P1150R3A	#3	6"	1	Bulk



NEW! PHILLIPS DOUBLE END BITS

PART NUMBER	TIP SIZE	LENGTH	PIECE COUNT	PACKAGING
P165P2P2B	P2 + P2	2-9/16"	1	Bulk
P165P2P2B-C1	P2 + P2	2-9/16"	1	Carded



NEW! SQUARE DOUBLE END BITS

PART NUMBER	TIP SIZE	LENGTH	PIECE COUNT	PACKAGING
P165R2R2B	R2 + R2	2-9/16"	1	Bulk
P165R2R2B-C1	R2 + R2	2-9/16"	1	Carded

TORX® is a registered trademark of Acument Global Technologies, LLC.





1/4"

NEW! TORX® INSERT BITS

PART NUMBER	TIP SIZE	LENGTH	PIECE COUNT	PACKAGING
P125T10A	10	1"	1	Bulk
P125T15A	15	1"	1	Bulk
P125T20A	20	1"	1	Bulk
P125T25A	25	1"	1	Bulk
P125T25A-C1	25	1"	1	Carded
P125T27A	27	1"	1	Bulk
P125T30A	30	1"	1	Bulk
P125T40A	40	1"	1	Bulk



1/4"

NEW! HEX INSERT BITS

PART NUMBER	TIP SIZE	LENGTH	PIECE COUNT	PACKAGING
P125H1064A	5/32"	1"	1	Bulk
P125H1264A	3/16"	1"	1	Bulk
P125H1464A	7/32"	1"	1	Bulk
P125H1664A	1/4"	1"	1	Bulk
P125H030A	3mm	1"	1	Bulk
P125H040A	4mm	1"	1	Bulk
P125H050A	5mm	1"	1	Bulk
P125H060A	6mm	1"	1	Bulk



1/4"

NEW! TORX® POWER BITS

PART NUMBER	TIP SIZE	LENGTH	PIECE COUNT	PACKAGING
P150T10A	10	2"	1	Bulk
P150T10A-C1	10	2"	1	Carded
P150T15A	15	2"	1	Bulk
P150T15A-C1	15	2"	1	Carded
P150T20A	20	2"	1	Bulk
P150T20A-C1	20	2"	1	Carded
P150T20A-C2	20	2"	2	Carded
P150T25A	25	2"	1	Bulk
P150T25A-C1	25	2"	1	Carded
P150T25A-C2	25	2"	2	Carded
P150T25A-C5	25	2"	5	Carded
P150T27A	27	2"	1	Bulk
P150T27A-C1	27	2"	1	Carded
P150T30A	30	2"	1	Bulk
P150T30A-C1	30	2"	1	Carded
P150T40A	40	2"	1	Bulk



1/4"

NEW! SLOTTED INSERT BITS

PART NUMBER	TIP SIZE	LENGTH	PIECE COUNT	PACKAGING
P125F04A	4F-5R	1"	1	Bulk
P125F06A	6F-8R	1"	1	Bulk
P125F08A	8F-10R	1"	1	Bulk

F = Flat Head Screw
R = Round Head Screw

IMPACTTECH™ DRIVER BITS

IMPACTTECH™ SKIN CARD PACKAGING

C1 = 1 Piece per Card
C2 = 2 Pieces per Card
C5 = 5 Pieces per Card

Note:
All carded items are packed 6 pcs. per box / 24 pcs. per carton

Minimum order for all carded items is 6 pcs. (1 box)

Merchandising options available on pages 85 and 87



1/4"

NEW! PHILLIPS SQUARE-DRIV® INSERT BITS

PART NUMBER	TIP SIZE	LENGTH	PIECE COUNT	PACKAGING
P125PSD22	2-2	1"	1	Bulk



Phillips Square-Drive® is a registered trademark of Phillips Screw Company
TORX is a registered trademark of Acument Global Technologies, LLC.

NEW! IMPACTECH™ BIT-PAK DISPLAYS

PART NUMBER	DESCRIPTION	PIECE COUNT	CASE QTY
P125P2A-25PK-12	Phillips #2 Insert Bit x 1"	25	12
P125R2A-25PK-12	Square #2 Insert Bit x 1"	25	12
P150P2A-15PK-12	Phillips #2 Power Bit x 2"	15	12
P150R2A-15PK-12	Square #2 Power Bit x 2"	15	12



NEW! IMPACTECH™ COUNTERTOP JARS

PART NUMBER	DESCRIPTION	PIECE COUNT
P125P2A-F250	Phillips #2 Insert Bit x 1"	250
P125R2A-F250	Square #2 Insert Bit x 1"	250
P150P2A-F100	Phillips #2 Power Bit x 2"	100
P150R2A-F100	Square #2 Power Bit x 2"	100
P165P2P2B-F100	Phillips #2 Double End Power Bit x 2-9/16"	100
P165R2R2B-F100	Square #2 Double End Power Bit x 2-9/16"	100
P175MH1CD2-F50	Magnetic Bit Holder x 3"	50
P175MH1QD2-F50	Quick Release Magnetic Bit Holder x 3"	50



IMPACTECH™ ACCESSORIES



NEW! QUICK RELEASE MAGNETIC BIT HOLDERS

PART NUMBER	OPENING SIZE	LENGTH	PIECE COUNT	PACKAGING
P175MH1QD2	1/4"	3"	1	Bulk
P175MH1QD2-C1	1/4"	3"	1	Carded



NEW! MAGNETIC BIT HOLDERS

PART NUMBER	OPENING SIZE	LENGTH	PIECE COUNT	PACKAGING
P175MH1CD2	1/4"	3"	1	Bulk
P175MH1CD2-C1	1/4"	3"	1	Carded
P1150MH1CD2	1/4"	6"	1	Bulk
P1150MH1CD2-C1	1/4"	6"	1	Carded



NEW! MAGNETIC NUTSETTERS

PART NUMBER	SIZE	LENGTH	PIECE COUNT	PACKAGING
P165MN416	1/4"	2-9/16"	1	Bulk
P165MN416-C1	1/4"	2-9/16"	1	Carded
P165MN516	5/16"	2-9/16"	1	Bulk
P165MN516-C1	5/16"	2-9/16"	1	Carded
P165MN616	3/8"	2-9/16"	1	Bulk
P165MN616-C1	3/8"	2-9/16"	1	Carded
P165MN716	7/16"	2-9/16"	1	Bulk
P165MN716-C1	7/16"	2-9/16"	1	Carded
P165MN816	1/2"	2-9/16"	1	Bulk
P165MN816-C1	1/2"	2-9/16"	1	Carded



NEW! QUICK RELEASE ADAPTER

PART NUMBER	MALE SQUARE	LENGTH	PIECE COUNT	PACKAGING
P175QADB38	3/8"	3"	1	Bulk

TORX® is a registered trademark of Acument Global Technologies, LLC.





NEW!

IMPACTECH™ 19PC SET

PART NUMBER	DESCRIPTION	PIECE COUNT
P19-1DB	IMPACTECH™ SET	19
<i>CONTENTS:</i>		
P125P2A	Phillips #2 x 1"	8
P125R1A	Square #1 x 1"	1
P125R2A	Square #2 x 1"	2
P125R3A	Square #3 x 1"	1
P150P2A	Phillips #2 x 2"	2
P150P3A	Phillips #3 x 2"	1
P150R2A	Square #2 x 2"	1
P175MH1CD2	Mag Bit Holder x 3"	1
P165MN416	1/4" Mag Nutsetter	1
P165MN516	5/16" Mag Nutsetter	1

NEW!

IMPACTECH™ 21PC SET

PART NUMBER	DESCRIPTION	PIECE COUNT
P21-1DB	IMPACTECH™ SET	21
<i>CONTENTS:</i>		
P125P1A	Phillips #1 x 1"	1
P125P2A	Phillips #2 x 1"	1
P125P3A	Phillips #3 x 1"	1
P125R1A	Square #1 x 1"	1
P125R2A	Square #2 x 1"	1
P125R3A	Square #3 x 1"	1
P125T20A	Torx 20 x 1"	1
P125T25A	Torx 25 x 1"	1
P125T27A	Torx 27 x 1"	1
P125T30A	Torx 30 x 1"	1
P150P1A	Phillips #1 x 2"	1
P150P2A	Phillips #2 x 2"	1
P150R1A	Square #1 x 2"	1
P150R2A	Square #2 x 2"	1
P1150P2A	Phillips #2 x 6"	1
P1150R2A	Square #2 x 6"	1
P175MH1CD2	Mag Bit Holder x 3"	1
P165MN416	1/4" Mag Nutsetter	1
P165MN516	5/16" Mag Nutsetter	1
P165MN616	3/8" Mag Nutsetter	1
P165MN716	7/16" Mag Nutsetter	1

NEW!

IMPACTECH™ 34PC SET

PART NUMBER	DESCRIPTION	PIECE COUNT
P34-1DB	IMPACTECH™ SET	34
<i>CONTENTS:</i>		
P125P1A	Phillips #1 x 1"	1
P125P2A	Phillips #2 x 1"	6
P125P3A	Phillips #3 x 1"	1
P125R1A	Square #1 x 1"	1
P125R2A	Square #2 x 1"	3
P125R3A	Square #3 x 1"	1
P125H1064A	Hex 5/32" x 1"	1
P125H1264A	Hex 3/16" x 1"	1
P125H1464A	Hex 7/32" x 1"	1
P125H1664A	Hex 1/4" x 1"	1
P125F04A	Slotted 4-5 x 1"	1
P125F06A	Slotted 6-8 x 1"	1
P125F08A	Slotted 8-10 x 1"	1
P125T20A	Torx 20 x 1"	1
P125T25A	Torx 25 x 1"	1
P125T27A	Torx 27 x 1"	1
P125T30A	Torx 30 x 1"	1
P150P1A	Phillips #1 x 2"	1
P150P2A	Phillips #2 x 2"	5
P150P3A	Phillips #3 x 2"	1
P150R2A	Square #2 x 2"	2
P175MH1CD2	Mag Bit Holder x 3"	1

IMPACTECH™ SETS



All sets packaged in double blisters



TORX® is a registered trademark of Acument Global Technologies, LLC.



- Driver bits consistently meet the challenges of even the most demanding industrial & construction applications
- All bits are made from S2 modified shock resistant steel
- Bit tips are CNC machined for excellent fit in the fastener recess and reduced camout
- Several bits are available in a choice of two hardness levels, Standard and Extra Hard
- Extended reach bits available up to 12"
- Variety of finishes available for different applications: Gunmetal Grey, Titanium Nitride, Diamond Tip and Stainless Steel

PHILLIPS HEAD SIZING CHART

		WOOD SCREW SIZE		MACHINE SCREW SIZE			SHEET METAL SCREWS
Point Size	Body Diam	Flat Oval	Round	Flat Oval Binding	Round Fillister	Truss Brazier Button	Flat, Round, Oval, Stove Binding
0		No. 0 & 1	No. 0 & 1	No. 0 & 1	No. 0 & 1	No. 0 & 1	No. 0 & 1
1	3/16	2, 3, 4	2, 3, 4	2, 3, 4	2, 3, 4	2, 3, 4	2, 3, 4
2	1/4	5, 6, 7, 8, 9	5, 6, 7, 8, 9, 10	5, 6, 8, 10	5, 6, 8, 10	6, 8, 10	5, 6, 7, 8, 10
3	5/16	10, 12, 14, 16	12, 14, 16	12, 1/4	12, 1/4, 5/16	12, 1/4	12, 14
4	3/8	18, 20, 24	18, 20, 24	5/16, 3/8, 7/16, 1/2	3/8, 7/16, 1/2	5/16, 3/8, 7/16, 1/2	

IMPORTANT: This table will allow you to determine the Phillips point size to use with any Phillips screw or bolt. The No. 2 and No. 3 point sizes cover the range of the most commonly used Phillips screws.

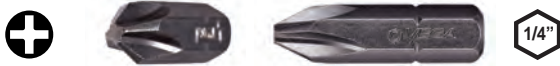

PHILLIPS INSERT BITS - FULL BODY

PART NUMBER	TIP SIZE	LENGTH
125P1F	#1	1"
125P1FX	#1	1"
125P2F	#2	1"
125P2FX	#2	1"
125P3F	#3	1"
125P3FX	#3	1"



PHILLIPS INSERT BITS - ACR®

PART NUMBER	TIP SIZE	LENGTH
125P1CR	#1	1"
125P2CR	#2	1"
125P2RCR	#2R	1"
125P3CR	#3	1"



PHILLIPS INSERT BITS

PART NUMBER	TIP SIZE	LENGTH
125P00A	#00	1"
125P0A	#0	1"
125P1A	#1	1"
125P1AX	#1	1"
125P2A	#2	1"
125P2AX	#2	1"
125P3A	#3	1"
125P3AX	#3	1"
125P4A*	#4	1"
132P3A*	#3	1-1/4"
132P4A*	#4	1-1/4"
138P2A	#2	1-1/2"
150P2D	#2	2"



PHILLIPS INSERT BITS - DRYWALL INDENTER

PART NUMBER	TIP SIZE	LENGTH
125P2C	#2	1"



PHILLIPS INSERT BITS - 5/16 SHANK

PART NUMBER	TIP SIZE	LENGTH
230P1F	#1	1-1/4"
230P2F	#2	1-1/4"
230P3F	#3	1-1/4"
230P4F	#4	1-1/4"
270P1F	#1	2-3/4"
270P2F	#2	2-3/4"
270P3F	#3	2-3/4"
270P4F	#4	2-3/4"



PHILLIPS INSERT BITS - REDUCED

PART NUMBER	TIP SIZE	LENGTH
125P1R	#1	1"
125P2R	#2	1"
125P2RX	#2	1"

X-HARD - An x at the end of a part number denotes an extra hard bit.

* Denotes bullnose type bit

ACR® is a registered trademark of the Phillips Screw Co.



PHILLIPS POWER BITS

PART NUMBER	TIP SIZE	LENGTH
150P00A	#00	2"
150P0A	#0	2"
150P1A	#1	2"
150P1AX	#1	2"
150P2A	#2	2"
150P2AX	#2	2"
NEW! 150P2R	#2	2"
150P3A	#3	2"
150P3A-2*	#3	2"
150P3AX	#3	2"
170P1A	#1	2-3/4"
170P1AX	#1	2-3/4"
170P2A	#2	2-3/4"
170P2AX	#2	2-3/4"
170P3A	#3	2-3/4"
170P3A-2*	#3	2-3/4"
170P3AX	#3	2-3/4"
170P4A	#4	2-3/4"
NEW! 170P4F	#4	2-3/4"
190P0A-SP	#0	3-1/2"
190P1A	#1	3-1/2"
190P1AX	#1	3-1/2"
190P2A	#2	3-1/2"
190P2AX	#2	3-1/2"
190P3A	#3	3-1/2"
190P3A-2*	#3	3-1/2"
190P3AX	#3	3-1/2"
NEW! 1115P2A	#2	4-1/2"
1150P1A	#1	6"
1150P1AX	#1	6"
1150P2A	#2	6"
1150P2AX	#2	6"
1150P3A	#3	6"
1150P3A-2*	#3	6"
1150P3AX	#3	6"
1200P2A	#2	8"
1250P2A	#2	10"
1300P2A	#2	12"

XHARD - An x at the end of a part number denotes an extra hard bit.

* Denotes bullnose type bit

ACR® is a registered trademark of the Phillips Screw Co.

Extended Reach Options Available up to 12"



PHILLIPS POWER BITS - ACR®

PART NUMBER	TIP SIZE	LENGTH
NEW! 150P0ACR	#0	2"
150P1ACR	#1	2"
150P2ACR	#2	2"
150P3ACR	#3	2"
170P1ACR	#1	2-3/4"
170P2ACR	#2	2-3/4"
170P3ACR	#3	2-3/4"
175P1ACR	#1	3"
190P1ACR	#1	3-1/2"
190P2ACR	#2	3-1/2"
190P3ACR	#3	3-1/2"
1150P1ACR	#1	6"
1150P2ACR	#2	6"
1150P3ACR	#3	6"



PHILLIPS POWER BITS - DRYWALL INDENTER

PART NUMBER	TIP SIZE	LENGTH
150P2C	#2	2"



PHILLIPS POWER BITS - 7/16 SHANK

PART NUMBER	TIP SIZE	LENGTH
390P2A	#2	3-1/2"
390P3A	#3	3-1/2"
390P4A	#4	3-1/2"



PHILLIPS DOUBLE END BITS

PART NUMBER	TIP SIZE	LENGTH
150P1F6D	P1 + Slotted 3/16"	2"
150P2F55D	P2 + Slotted 5.5mm	2"
150P2F8D	P2 + Slotted 1/4"	2"
150P2P2D	P2 + P2	2"
150P3F10D	P3 + Slotted 9/32"	2"
150P2P2B	P2 + P2	2"

Part numbers ending in B have ball grooves

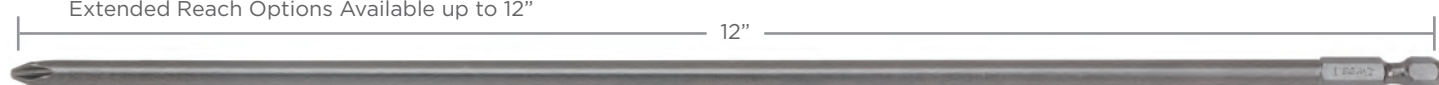

+ PHILLIPS BITS



PHILLIPS 10-32 THREADED BITS

PART NUMBER	TIP SIZE	LENGTH
103238P2X	#2	1-1/2"
NEW! 103245P2X	#2	2"



PHILLIPS 12-24 THREADED BITS

PART NUMBER	TIP SIZE	LENGTH
122430P2	#2	1-3/16"
122430P2X	#2	1-3/16"



PHILLIPS 1/4"-24 THREADED BITS

PART NUMBER	TIP SIZE	LENGTH
142438P2X	#2	1-3/16"



PHILLIPS 8-32 THREADED BITS

PART NUMBER	TIP SIZE	LENGTH
83230P2X	#2	1-3/16"



PHILLIPS BIT FINDERS

PART NUMBER	TIP SIZE	LENGTH
BFP1	#1	3-1/2"
BFP2	#2	3-1/2"
BFP3	#3	3-1/2"



X-HARD - Extra Hard bits undergo an extended heat treatment process giving them superior strength vs regular bits.

An x at the end of a part number denotes an extra hard bit.



PHILLIPS SOCKET BITS - 1/4" SQUARE DRIVE

PART NUMBER	TIP SIZE	LENGTH
120P1SB	#1	3/4"
120P2SB	#2	3/4"
120P3SB	#3	3/4"
120P4SB	#4	3/4"
150P2SK	#2	2"



PHILLIPS SOCKET BITS - 3/8" SQUARE DRIVE

PART NUMBER	TIP SIZE	LENGTH
228P2SB	#2	1"
228P3SB	#3	1"
228P4SB	#4	1"
267P2SK	#2	2-5/8"
267P3SK	#3	2-5/8"
267P4SK	#4	2-5/8"



PHILLIPS SOCKET BITS - 1/2" SQUARE DRIVE

PART NUMBER	TIP SIZE	LENGTH
338P3SB	#3	1-1/2"
338P4SB	#4	1-1/2"
373P3SK	#3	2-7/8"
373P4SK	#4	2-7/8"



PHILLIPS TAMPER INSERT BITS

PART NUMBER	TIP SIZE	LENGTH
125TP1A	#1	1"
125TP2A	#2	1"
125TP3A	#3	1"

PHILLIPS | PHILLIPS TAMPER BITS



SQUARE INSERT BITS

PART NUMBER	TIP SIZE	LENGTH
125R0A	#0	1"
125R1A	#1	1"
125R1AX	#1	1"
125R2A	#2	1"
125R2AX	#2	1"
125R3A	#3	1"
125R3AX	#3	1"
125R4A	#4	1"



SQUARE INSERT BITS 2 PC CONSTRUCTION

PART NUMBER	TIP SIZE	LENGTH
NEW! 125R0C	#0	1"
125R1C	#1	1"
125R2C	#2	1"
125R3C	#3	1"



SQUARE POWER BITS 2 PC CONSTRUCTION

PART NUMBER	TIP SIZE	LENGTH
150R1C	#1	2"
150R2C	#2	2"
NEW! 150R2CU	#2	2"
150R3C	#3	2"
170R1C	#1	2-3/4"
170R2C	#2	2-3/4"
170R3C	#3	2-3/4"
NEW! 175R2C	#2	3"
NEW! 175R2CU	#2	3"
NEW! 175R3C	#3	3"
190R1C	#1	3-1/2"
190R2C	#2	3-1/2"
190R3C	#3	3-1/2"
NEW! 1100R2C	#2	4"
NEW! 1100R2CU	#2	4"
1150R1C	#1	6"
1150R2C	#2	6"
NEW! 1150R2CU	#2	6"
1150R3C	#3	6"



SQUARE POWER BITS

PART NUMBER	TIP SIZE	LENGTH
150R0A	#0	2"
150R1A	#1	2"
150R1AX	#1	2"
150R2A	#2	2"
150R2AX	#2	2"
150R3A	#3	2"
150R3AX	#3	2"
NEW! 170R0A	#0	2-3/4"
170R1A	#1	2-3/4"
170R1AX	#1	2-3/4"
170R2A	#2	2-3/4"
170R2AX	#2	2-3/4"
170R3A	#3	2-3/4"
170R3AX	#3	2-3/4"
190R1A	#1	3-1/2"
190R1AX	#1	3-1/2"
190R2A	#2	3-1/2"
190R2AX	#2	3-1/2"
190R3A	#3	3-1/2"
190R3AX	#3	3-1/2"
1150R1A	#1	6"
1150R1AX	#1	6"
1150R2A	#2	6"
1150R2AX	#2	6"
1150R3A	#3	6"
1150R3AX	#3	6"
1200R1A	#1	8"
1200R2A	#2	8"
1200R3A	#3	8"
1250R1A	#1	10"
1250R2A	#2	10"
1250R3A	#3	10"
1300R1A	#1	12"
1300R2A	#2	12"
1300R3A	#3	12"

X-HARD - An x at the end of a part number denotes an extra hard bit.

Part numbers ending in U denote an undersized bit, used for applications where the fastener has been painted.

Extended Reach Options Available up to 12"



SQUARE BITS



TORX® INSERT BITS		
PART NUMBER	TIP SIZE	LENGTH
125T05A	5	1"
125T06A	6	1"
125T07A	7	1"
125T08A	8	1"
125T09A	9	1"
125T10A	10	1"
125T15A	15	1"
125T20A	20	1"
125T25A	25	1"
125T27A	27	1"
125T30A	30	1"
125T40A	40	1"
125T45A*	45	1"
125T50A*	50	1"



TORX® INSERT BITS - 5/16" SHANK		
PART NUMBER	TIP SIZE	LENGTH
230T20A	20	1-1/4"
230T25A	25	1-1/4"
230T27A	27	1-1/4"
230T30A	30	1-1/4"
230T40A	40	1-1/4"
230T45A	45	1-1/4"
230T50A	50	1-1/4"
230T55A	55	1-1/4"
230T60A	60	1-1/4"



* Denotes a bullnose type bit where the tip of the bit has a larger diameter than the hex shank body



TORX® POWER BITS		
PART NUMBER	TIP SIZE	LENGTH
NEW! 150T05A	5	2"
150T06A	6	2"
150T07A	7	2"
150T08A	8	2"
150T09A	9	2"
150T10A	10	2"
150T15A	15	2"
150T20A	20	2"
150T25A	25	2"
150T27A	27	2"
150T30A	30	2"
150T40A	40	2"
150T45A	45	2"
NEW! 170T05A	5	2-3/4"
170T06A	6	2-3/4"
170T07A	7	2-3/4"
170T08A	8	2-3/4"
170T09A	9	2-3/4"
170T10A	10	2-3/4"
170T15A	15	2-3/4"
170T20A	20	2-3/4"
170T25A	25	2-3/4"
170T27A	27	2-3/4"
170T30A	30	2-3/4"
170T40A	40	2-3/4"
190T06A	6	3-1/2"
190T07A	7	3-1/2"
190T08A	8	3-1/2"
190T09A	9	3-1/2"
190T10A	10	3-1/2"
190T15A	15	3-1/2"
190T20A	20	3-1/2"
190T25A	25	3-1/2"
190T27A	27	3-1/2"
190T30A	30	3-1/2"
190T40A	40	3-1/2"
1150T06A	6	6"
1150T07A	7	6"
1150T08A	8	6"
1150T09A	9	6"
1150T10A	10	6"
1150T15A	15	6"
1150T20A	20	6"
1150T25A	25	6"
1150T27A	27	6"
1150T30A	30	6"
1150T40A	40	6"



NEW! **TORX®** POWER BITS - 7/16" SHANK

PART NUMBER	TIP SIZE	LENGTH
350T30A	30	2"
350T40A	40	2"
350T45A	45	2"
350T50A	50	2"
350T55A	55	2"
350T60A	60	2"
350T70A	70	2"



TORX® SOCKET BITS - 1/4" SQUARE DRIVE

PART NUMBER	TIP SIZE	LENGTH
120T08SB	8	3/4"
120T10SB	10	3/4"
120T15SB	15	3/4"
120T20SB	20	3/4"
120T25SB	25	3/4"
120T27SB	27	3/4"
120T30SB	30	3/4"
120T40SB	40	3/4"
120T45SB	45	3/4"



TORX® SOCKET BITS - 3/8" SQUARE DRIVE

PART NUMBER	TIP SIZE	LENGTH
228T25SB	25	1-1/8"
228T27SB	27	1-1/8"
228T30SB	30	1-1/8"
228T40SB	40	1-1/8"
228T45SB	45	1-1/8"
228T50SB	50	1-1/8"



TORX® SOCKET BITS - 1/2" SQUARE DRIVE

PART NUMBER	TIP SIZE	LENGTH
338T30SB	30	1-1/2"
338T40SB	40	1-1/2"
338T45SB	45	1-1/2"
338T50SB	50	1-1/2"
338T55SB	55	1-1/2"
338T60SB	60	1-1/2"

 **TORX®** BITS

TORX® is a registered trademark of Acument Global Technologies, LLC.



TORX® TAMPER INSERT BITS		
PART NUMBER	TIP SIZE	LENGTH
125TT05A	5	1"
125TT06A	6	1"
125TT07A	7	1"
125TT08A	8	1"
125TT09A	9	1"
125TT10A	10	1"
125TT15A	15	1"
125TT20A	20	1"
125TT25A	25	1"
125TT27A	27	1"
125TT30A	30	1"
125TT40A	40	1"
125TT45A*	45	1"



TORX® TAMPER POWER BITS		
PART NUMBER	TIP SIZE	LENGTH
150TT10A	10	2"
150TT15A	15	2"
150TT20A	20	2"
150TT25A	25	2"
150TT27A	27	2"
150TT30A	30	2"
150TT40A	40	2"
150TT45A	45	2"
170TT10A	10	2-3/4"
170TT15A	15	2-3/4"
170TT20A	20	2-3/4"
170TT25A	25	2-3/4"
170TT27A	27	2-3/4"
170TT30A	30	2-3/4"
170TT40A	40	2-3/4"
190TT10A	10	3-1/2"
190TT15A	15	3-1/2"
190TT20A	20	3-1/2"
190TT25A	25	3-1/2"
190TT27A	27	3-1/2"
190TT30A	30	3-1/2"
190TT40A	40	3-1/2"
1150TT10A	10	6"
1150TT15A	15	6"
1150TT20A	20	6"
1150TT25A	25	6"
1150TT27A	27	6"
1150TT30A	30	6"
1150TT40A	40	6"



TORX® TAMPER INSERT BITS - 5/16" SHANK		
PART NUMBER	TIP SIZE	LENGTH
230TT25A	25	1-1/4"
230TT27A	27	1-1/4"
230TT30A	30	1-1/4"
230TT40A	40	1-1/4"
230TT45A	45	1-1/4"
230TT50A	50	1-1/4"
230TT55A*	55	1-1/4"



* Denotes a bullnose type bit where the tip of the bit has a larger diameter than the hex shank body

TORX® TAMPER BITS



TORX® TAMPER SOCKET BITS - 1/4" SQUARE DRIVE

PART NUMBER	TIP SIZE	LENGTH
120TT08SB	8	3/4"
120TT10SB	10	3/4"
120TT15SB	15	3/4"
120TT20SB	20	3/4"
120TT25SB	25	3/4"
120TT27SB	27	3/4"
120TT30SB	30	3/4"
120TT40SB	40	3/4"



TORX® TAMPER SOCKET BITS - 3/8" SQUARE DRIVE

PART NUMBER	TIP SIZE	LENGTH
228TT25SB	25	1"
228TT27SB	27	1"
228TT30SB	30	1"
228TT40SB	40	1"
228TT45SB	45	1"
228TT50SB	50	1"



TORX® TAMPER SOCKET BITS - 1/2" SQUARE DRIVE

PART NUMBER	TIP SIZE	LENGTH
338TT30SB	30	1-1/2"
338TT40SB	40	1-1/2"
338TT45SB	45	1-1/2"
338TT50SB	50	1-1/2"
338TT55SB	55	1-1/2"
338TT60SB	60	1-1/2"

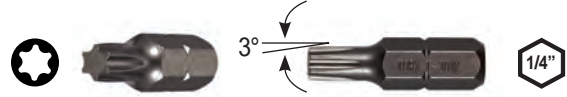

TORX® ALIGN INSERT BITS

PART NUMBER	TIP SIZE	LENGTH
125T10W	10	1"
125T15W	15	1"
125T20W	20	1"
125T25W	25	1"
125T30W	30	1"
125T40W	40	1"

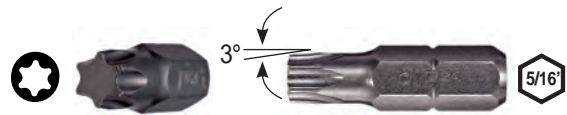

NEW! TORX® ALIGN INSERT BITS - 5/16" SHANK

PART NUMBER	TIP SIZE	LENGTH
230T30W	30	1-1/4"
230T45W	45	1-1/4"



TORX® ALIGN POWER BITS

PART NUMBER	TIP SIZE	LENGTH
150T10W	10	2"
150T15W	15	2"
150T20W	20	2"
150T25W	25	2"
150T27W	27	2"
150T30W	30	2"
170T10W	10	2-3/4"
170T15W	15	2-3/4"
170T20W	20	2-3/4"
170T25W	25	2-3/4"
170T27W	27	2-3/4"
170T30W	30	2-3/4"
170T40W	40	2-3/4"



TORX® ALIGN bits have a 3° tapered tip that creates a wedge fit with the fastener

TORX® TAMPER | TORX® ALIGN BITS



TORXplus® INSERT BITS

PART NUMBER	TIP SIZE	LENGTH
125IP10A	10	1"
125IP15A	15	1"
125IP20A	20	1"
125IP25A	25	1"
125IP27A	27	1"
125IP30A	30	1"
125IP40A	40	1"



NEW! TORXplus® TAMPER INSERT BITS

PART NUMBER	TIP SIZE	LENGTH
125IPR10	10	1"
125IPR15	15	1"
125IPR20	20	1"
125IPR25	25	1"
125IPR27	27	1"
125IPR30	30	1"
125IPR40	40	1"



TORXplus® INSERT BITS - 5/16" SHANK

PART NUMBER	TIP SIZE	LENGTH
230IP30A	30	1-1/4"
230IP40A	40	1-1/4"



NEW! TORXplus® INSERT BITS - 7/16" SHANK

PART NUMBER	TIP SIZE	LENGTH
350IP55A	55	2"

TORXplus® FEATURES

- Spreads driving force over larger area allowing for higher torque transmission
- Maximizes engagement between bit and fastener virtually eliminating camout
- Reduces tool slippage and application damage
- Reduces bit wear, extending tool life



TORX®

vs.



TORXplus®

TORXplus® | TORXplus® TAMPER BITS

TORXplus® is a registered trademark of Acument Global Technologies, LLC.

HEX HEAD SIZING CHART

INCH

Nominal Hex Size	Socket Head 1960 Series	Socket Head 1936 Series	Flat Head Cap Screws	Button Head Cap Screws	Set Screws	Shoulder Screws	Pressure Plugs	Allenuts	Low Head Cap Screws
0.050	0	0, 1	1, 2	3, 4	-	-	-	4	.050
1/16	1	2	3, 4	3, 4	5, 6	-	-	-	5, 6
5/64	2.3	3, 4	5, 6	5, 6	8	-	-	-	8
3/32	4.5	5, 6	8	8	10	-	-	-	10
7/64	6	-	-	-	-	-	-	-	-
1/8	-	8	10	10	1/4	1/4	-	4, 5	1/4
9/64	8	10	-	-	-	-	-	-	-
5/32	10	1/4	1/4	1/4	5/16	5/16	1/16	6	5/16
3/16	1/4	-	5/16	5/16	3/8	3/8	1/8	8, 10	3/8
7/32	-	5/16	3/8	3/8	7/16	-	-	-	7/16
1/4	5/16	-	7/16	-	1/2	1/2	1/4	1/4	1/2
5/16	3/8	3/8, 7/16	1/2	-	5/8	5/8	3/8	5/16	5/8
3/8	7/16, 1/2	1/2	5/8	-	3/4	3/4	1/2	3/8	-
7/16	-	-	-	-	-	-	-	7/16	-
1/2	5/8	5/8	3/4	-	7/8	1	-	1/2	-
9/16	-	3/4, 7/8	7/8	-	1, 1 1/8	-	3/4	-	-
5/8	3/4	1	1	-	1 1/4 1 3/8	1 1/4	1	5/8	-
3/4	7/8, 1	1 1/8 1 1/4 1 3/8	1 1/8	-	1 1/2	-	1 1/4	3/4	-
7/8	1 1/8 1 1/4	-	1 1/4 1 3/8	-	-	1 1/2	-	7/8	-
1	1 3/8 1 1/2	1 1/2	1 1/2	-	1 3/4, 2	1 3/4	1 1/2, 2	1	-
1 1/4	1 3/4	-	-	-	-	2	-	1 1/4	-
1 1/2	2	-	-	-	-	-	-	1 1/2	-
1 3/4	2 1/4 2 1/2	-	-	-	-	-	-	-	1 3/4
2	2 3/4	-	-	-	-	-	-	-	-

HEX HEAD SIZING CHART

METRIC

Nominal Hex Size	Socket Head 1960 Series	Flat Head Cap Screws	Button Head Cap Screws	Set Screws	Shoulder Screws	Allenuts	Low Head Cap Screws
1.5	M1.6 M1.7 M2	-	-	M3	-	-	-
2	M2.3 M2.5 M2.6	M3	M3	M4	-	-	-
2.5	M3	M4	M4	M5	-	-	-
3	M4	M5	M5	M6	6mm	M3	M4
4	M5	M6	M6	M8	8mm	M4	M5
5	M6	M8	M8	M10	10mm	M5	M6
6	M8	M10	M10	M12, M14	12mm	M6	M8
8	M10	M12	M12	M16	16mm	M8	M10
10	M12	M14, M16	-	M18	20mm	M10	M12
12	M14	M20	-	M20	-	M12	M14
14	M16	-	-	-	-	-	M16
17	M20	-	-	-	-	M16	M20, M22
19	M24	-	-	-	-	-	M24

HEX HEAD SIZING CHART



HEX INSERT BITS		
PART NUMBER	TIP SIZE	LENGTH
125H0464A	1/16"	1"
125H0564A	5/64"	1"
125H0664A	3/32"	1"
125H0764A	7/64"	1"
125H0864A	1/8"	1"
125H0964A	9/64"	1"
125H1064A	5/32"	1"
125H1264A	3/16"	1"
125H1464A	7/32"	1"
125H1664A	1/4"	1"
125H2064A	5/16"	1"



HEX INSERT BITS - 5/16" SHANK		
PART NUMBER	TIP SIZE	LENGTH
230H1064A	5/32"	1-1/4"
230H1264A	3/16"	1-1/4"
230H1464A	7/32"	1-1/4"
230H1664A	1/4"	1-1/4"
230H2064A	5/16"	1-1/4"
230H2464A	3/8"	1-1/4"



HEX POWER BITS - 7/16" SHANK		
PART NUMBER	TIP SIZE	LENGTH
350H0864A	1/8"	2"
350H1064A	5/32"	2"
350H1264A	3/16"	2"
350H1464A	7/32"	2"
350H1664A	1/4"	2"
350H2064A	5/16"	2"
350H2464A	3/8"	2"
350H2864A	7/16"	2"
350H3264A	1/2"	2"
350H3664A	9/16"	2"
NEW! 390H0864A	1/8"	3-1/2"
390H1064A	5/32"	3-1/2"
390H1264A	3/16"	3-1/2"
390H1464A	7/32"	3-1/2"
390H1664A	1/4"	3-1/2"
390H2064A	5/16"	3-1/2"
390H2464A	3/8"	3-1/2"



HEX POWER BITS		
PART NUMBER	TIP SIZE	LENGTH
150H0120A	1/20"	2"
150H0464A	1/16"	2"
150H0564A	5/64"	2"
150H0664A	3/32"	2"
150H0764A	7/64"	2"
150H0864A	1/8"	2"
150H0964A	9/64"	2"
150H1064A	5/32"	2"
150H1264A	3/16"	2"
150H1464A	7/32"	2"
150H1664A	1/4"	2"
150H2064A	5/16"	2"
170H0564A	5/64"	2-3/4"
170H0664A	3/32"	2-3/4"
170H0764A	7/64"	2-3/4"
170H0864A	1/8"	2-3/4"
170H0964A	9/64"	2-3/4"
170H1064A	5/32"	2-3/4"
170H1264A	3/16"	2-3/4"
170H1464A	7/32"	2-3/4"
170H1664A	1/4"	2-3/4"
190H0564A	5/64"	3-1/2"
190H0664A	3/32"	3-1/2"
190H0764A	7/64"	3-1/2"
190H0864A	1/8"	3-1/2"
190H0964A	9/64"	3-1/2"
190H1064A	5/32"	3-1/2"
190H1264A	3/16"	3-1/2"
190H1464A	7/32"	3-1/2"
190H1664A	1/4"	3-1/2"
1150H0564A	5/64"	6"
1150H0664A	3/32"	6"
1150H0764A	7/64"	6"
1150H0864A	1/8"	6"
1150H0964A	9/64"	6"
1150H1064A	5/32"	6"
1150H1264A	3/16"	6"
1150H1464A	7/32"	6"
1150H1664A	1/4"	6"

HEX BITS - INCH



HEX INSERT BITS

PART NUMBER	TIP SIZE	LENGTH
125H015A	1.5mm	1"
125H020A	2mm	1"
125H025A	2.5mm	1"
125H030A	3mm	1"
125H040A	4mm	1"
125H050A	5mm	1"
125H060A	6mm	1"
125H070A	7mm	1"
125H080A	8mm	1"



HEX POWER BITS - 7/16" SHANK

PART NUMBER	TIP SIZE	LENGTH
350H040A	4mm	2"
350H050A	5mm	2"
350H060A	6mm	2"
350H080A	8mm	2"
350H100A	10mm	2"
NEW! 350H110A	11mm	2"
350H120A	12mm	2"
350H140A	14mm	2"
350H170A	17mm	2"
350H190A	19mm	2"
390H040A	4mm	3-1/2"
390H050A	5mm	3-1/2"
390H060A	6mm	3-1/2"
390H080A	8mm	3-1/2"
390H100A	10mm	3-1/2"



HEX POWER BITS

PART NUMBER	TIP SIZE	LENGTH
150H020A	2mm	2"
150H025A	2.5mm	2"
150H030A	3mm	2"
150H040A	4mm	2"
150H050A	5mm	2"
150H060A	6mm	2"
170H025A	2.5mm	2-3/4"
170H030A	3mm	2-3/4"
170H040A	4mm	2-3/4"
170H050A	5mm	2-3/4"
190H025A	2.5mm	3-1/2"
190H030A	3mm	3-1/2"
190H040A	4mm	3-1/2"
190H050A	5mm	3-1/2"
190H060A	6mm	3-1/2"
1150H025A	2.5mm	6"
1150H030A	3mm	6"
1150H040A	4mm	6"
1150H050A	5mm	6"

Combine with square drive bit holders on page 42 to form socket bit assemblies

Socket Bit Assembly Example



INCH



HEX SOCKET BITS -
1/4" SQUARE DRIVE

PART NUMBER	TIP SIZE	LENGTH
120H0864SB	1/8"	3/4"
120H1064SB	5/32"	3/4"
120H1264SB	3/16"	3/4"
120H1464SB	7/32"	3/4"
120H1664SB	1/4"	3/4"
120H2064SB	5/16"	3/4"
120H2464SB	3/8"	3/4"

METRIC



HEX SOCKET BITS -
1/4" SQUARE DRIVE

PART NUMBER	TIP SIZE	LENGTH
120H030SB	3mm	3/4"
120H040SB	4mm	3/4"
120H050SB	5mm	3/4"
120H060SB	6mm	3/4"
120H070SB	7mm	3/4"
120H080SB	8mm	3/4"
120H100SB	10mm	3/4"



HEX SOCKET BITS -
3/8" SQUARE DRIVE

PART NUMBER	TIP SIZE	LENGTH
228H1064SB	5/32"	1"
228H1264SB	3/16"	1"
228H1464SB	7/32"	1"
228H1664SB	1/4"	1"
228H2064SB	5/16"	1"
228H2464SB	3/8"	1"



HEX SOCKET BITS -
3/8" SQUARE DRIVE

PART NUMBER	TIP SIZE	LENGTH
228H040SB	4mm	1"
228H050SB	5mm	1"
228H060SB	6mm	1"
228H070SB	7mm	1"
228H080SB	8mm	1"
228H100SB	10mm	1"



HEX SOCKET BITS -
1/2" SQUARE DRIVE

PART NUMBER	TIP SIZE	LENGTH
338H1664SB	1/4"	1-1/2"
338H2064SB	5/16"	1-1/2"
338H2464SB	3/8"	1-1/2"
338H2864SB	7/16"	1-1/2"
338H3264SB	1/2"	1-1/2"
338H3664SB	9/16"	1-1/2"



HEX SOCKET BITS -
1/2" SQUARE DRIVE

PART NUMBER	TIP SIZE	LENGTH
338H060SB	6mm	1-1/2"
338H070SB	7mm	1-1/2"
338H080SB	8mm	1-1/2"
338H100SB	10mm	1-1/2"
338H120SB	12mm	1-1/2"
338H140SB	14mm	1-1/2"

HEX SOCKET BITS

INCH



HEX TAMPER INSERT BITS

PART NUMBER	TIP SIZE	LENGTH
NEW! 125HT0464A	1/16"	1"
125HT0564A	5/64"	1"
125HT0664A	3/32"	1"
125HT0764A	7/64"	1"
125HT0864A	1/8"	1"
125HT0964A	9/64"	1"
125HT1064A	5/32"	1"
125HT1264A	3/16"	1"
125HT1464A	7/32"	1"
125HT1664A	1/4"	1"
125HT2064A	5/16"	1"

METRIC



HEX TAMPER INSERT BITS

PART NUMBER	TIP SIZE	LENGTH
125HT015A	1.5mm	1"
125HT020A	2mm	1"
125HT025A	2.5mm	1"
125HT030A	3mm	1"
125HT040A	4mm	1"
125HT050A	5mm	1"
125HT060A	6mm	1"
125HT070A	7mm	1"
125HT080A	8mm	1"



HEX TAMPER POWER BITS

PART NUMBER	TIP SIZE	LENGTH
150HT0664A	3/32"	2"
150HT0764A	7/64"	2"
150HT0864A	1/8"	2"
150HT0964A	9/64"	2"
150HT1064A	5/32"	2"
150HT1264A	3/16"	2"
150HT1464A	7/32"	2"
150HT1664A	1/4"	2"



HEX BALL INSERT BITS

PART NUMBER	TIP SIZE	LENGTH
125BP0664A	3/32"	1"
125BP0764A	7/64"	1"
125BP0864A	1/8"	1"
125BP0964A	9/64"	1"
125BP1064A	5/32"	1"
125BP1264A	3/16"	1"
125BP1464A	7/32"	1"
125BP1664A	1/4"	1"
125BP2064A*	5/16"	1"

* Denotes bullnose type bit



The Hex Ball design allows you to fasten at different angles which is helpful in hard to reach or limited space applications

SLOTTED SCREW SIZING CHART

Note: When ordering slotted bits, remember that head sizes and slot widths of hardened, self tapping and sheet metal screws do not conform to the same specifications as standard wood or machine screws shown in the chart below. Also, because of variations in dimensions among screws from different manufacturers, bits should be ordered to the head and slot size as opposed to the screw size.

HEAD DIAMETER

SCREW SIZES	FLAT HEAD		ROUND HEAD		TRUSS HEAD	BINDING HEAD	FILLISTER		PAN HEAD	WIDTH OF SLOT
	WOOD	MACHINE	WOOD	MACHINE			CAP	MACHINE		
1	.146	.146	.138	.138				.118		.026
	.130	.130	.122	.122				.104		.019
2	.172	.172	.162	.162	.194	.181		.140	.167	.031
	.156	.156	.146	.146	.180	.171		.124	.155	.023
3	.199	.199	.187	.187	.226	.208		.161	.193	.035
	.181	.181	.169	.169	.211	.197		.145	.180	.027
4	.225	.225	.211	.211	.257	.235		.183	.219	.039
	.207	.207	.193	.193	.241	.223		.166	.205	.031
5	.252	.252	.236	.236	.289	.263		.205	.245	.043
	.232	.232	.217	.217	.272	.249		.187	.231	.035
6	.279	.279	.260	.260	.321	.290		.226	.270	.048
	.257	.257	.240	.240	.303	.275		.208	.256	.039
7	.305		.285		.352				.296	.048
	.283		.264		.333				.281	.039
8	.332	.332	.309	.309	.384	.344		.270	.322	.054
	.308	.308	.287	.287	.364	.326		.250	.306	.045
9	.358		.334							.054
	.334		.311							.045
10	.385	.385	.359	.359	.448	.339		.313	.373	.060
		.359	.334	.334	.425	.378		.292	.357	.050
12	.438	.438	.408	.408	.511	.454		.357	.425	.067
	.410	.410	.382	.382	.487	.430		.334	.407	.056
14	.491		.457							.075
	.461		.424							.064
1/4"		.507		.472	.573	.513	.375	.414	.492	.075
		.477		.443	.548	.488	.363	.399	.473	.064
16	.544		.506							.075
	.512		.476							.064
18	.597		.555							.084
	.563		.523							.072
5/16"		.635		.590	.699	.641	.437	.518	.615	.084
		.600		.557	.666	.609	.424	.490	.594	.072
20	.650		.604							.084
	.614		.570							.072
24	.756		.702							.094
	.716		.664							.081
3/8"		.762		.708	.823	.769	.562	.622	.740	.094
		.722		.670	.787	.731	.547	.590	.716	.081

SLOTTED SCREW SIZING CHART



SLOTTED INSERT BITS

PART NUMBER	SCREW SIZE	TIP SIZE (T x D)	LENGTH
125F01A	0F-1R	.024 x .109	1"
125F02A	1F-2R	.020 x .138	1"
125F03A	2F-3R	.028 x .140	1"
125F04A	3F-4R	.032 x .156	1"
125F05A	4F-5R	.033 x .182	1"
125F06A	5F-6R	.036 x .232	1"
125F08A	6F-8R	.039 x .250	1"
125F10A	8F-10R	.042 x .281	1"
125F12A	10F-12R	.046 x .312	1"
125F14A	12F-14R	.050 x .360	1"
138F12A	10F-12R	.046 x .312	1-1/2"
138F16A	14F-16R	.055 x .360	1-1/2"



NEW!

SLOTTED INSERT BITS - 5/16" SHANK

PART NUMBER	SCREW SIZE	TIP SIZE (T x D)	LENGTH
238F04A	3F-4R	.032 x .156	1-1/2"
238F06A	5F-6R	.036 x .218	1-1/2"
238F08A	6F-7R	.039 x .250	1-1/2"
238F10A	8F-10R	.046 x .281	1-1/2"
238F12A	10F-12R	.052 x .355	1-1/2"
238F14A	12F-14R	.056 x .355	1-1/2"



SLOTTED BIT FINDERS

PART NUMBER	SCREW SIZE	TIP SIZE (T x D)	LENGTH
BF5	4F-6R	.036 x .190	3-3/4"
BF6	6F-8R	.038 x .240	3-3/4"
BF8	8F-10R	.042 x .290	3-3/4"
BF10	10F-12R	.046 x .350	3-3/4"
BF12	12F-14R	.050 x .395	3-3/4"
BF14	14F-16R	.055 x .457	3-3/4"



SLOTTED BIT FINDERS - 7/16" SHANK

PART NUMBER	SCREW SIZE	TIP SIZE (T x D)	LENGTH
BBF12	12F-14R	.050 x .395	3-7/8"
BBF14	14F-16R	.055 x .457	3-7/8"
BBF16	16F-20R	.060 x .500	3-7/8"
BBF20	20F-22R	.062 x .545	3-7/8"



SLOTTED POWER BITS

PART NUMBER	SCREW SIZE	TIP SIZE (T x D)	LENGTH
150F02A	1F-2R	.020 x .138	2"
150F03A	2F-3R	.028 x .140	2"
150F04A	3F-4R	.032 x .156	2"
150F05A	4F-5R	.033 x .182	2"
150F06A	5F-6R	.036 x .232	2"
150F08A	6F-8R	.039 x .250	2"
150F10A	8F-10R	.042 x .281	2"
150F12A	10F-12R	.046 x .312	2"
150F14A	12F-14R	.050 x .360	2"
170F02A	1F-2R	.020 x .138	2-3/4"
170F03A	2F-3R	.028 x .140	2-3/4"
170F04A	3F-4R	.032 x .156	2-3/4"
170F05A	4F-5R	.033 x .182	2-3/4"
170F06A	5F-6R	.036 x .232	2-3/4"
170F08A	6F-8R	.039 x .250	2-3/4"
170F10A	8F-10R	.042 x .281	2-3/4"
170F12A	10F-12R	.046 x .312	2-3/4"
170F14A	12F-14R	.050 x .360	2-3/4"
170F16A	14F-16R	.055 x .360	2-3/4"
190F02A	1F-2R	.020 x .138	3-1/2"
190F03A	2F-3R	.028 x .140	3-1/2"
190F04A	3F-4R	.032 x .156	3-1/2"
190F05A	4F-5R	.033 x .182	3-1/2"
190F06A	5F-6R	.036 x .232	3-1/2"
190F08A	6F-8R	.039 x .250	3-1/2"
190F10A	8F-10R	.042 x .281	3-1/2"
190F12A	10F-12R	.046 x .312	3-1/2"
190F14A	12F-14R	.050 x .360	3-1/2"
1150F02A	1F-2R	.020 x .138	6"
1150F03A	2F-3R	.028 x .140	6"
1150F04A	3F-4R	.032 x .156	6"
1150F05A	4F-5R	.033 x .182	6"
1150F06A	5F-6R	.036 x .232	6"
1150F08A	6F-8R	.039 x .250	6"
1150F10A	8F-10R	.042 x .281	6"
1150F12A	10F-12R	.046 x .312	6"
1150F14A	12F-14R	.050 x .360	6"

F = Flat Head Screw
R = Round Head Screw

 **SLOTTED BITS**



POZIDRIV® INSERT BITS		
PART NUMBER	TIP SIZE	LENGTH
125Z1A	#1	1"
125Z2A	#2	1"
125Z3A	#3	1"



POZIDRIV® INSERT BITS - ACR®		
PART NUMBER	TIP SIZE	LENGTH
125Z2CR	#2	1"



POZIDRIV® INSERT BITS - 5/16" SHANK		
PART NUMBER	TIP SIZE	LENGTH
230Z2F	#2	1-1/4"
230Z3F	#3	1-1/4"
230Z4F	#4	1-1/4"



POZIDRIV® POWER BITS		
PART NUMBER	TIP SIZE	LENGTH
150Z1A	#1	2"
150Z2A	#2	2"
150Z3A	#3	2"
170Z1A	#1	2-3/4"
170Z2A	#2	2-3/4"
170Z3A	#3	2-3/4"
190Z1A	#1	3-1/2"
190Z2A	#2	3-1/2"
190Z3A	#3	3-1/2"
1150Z1A	#1	6"
1150Z2A	#2	6"
1150Z3A	#3	6"



POZIDRIV® POWER BITS - ACR®		
PART NUMBER	TIP SIZE	LENGTH
150Z2ACR	#2	2"
170Z2ACR	#2	2-3/4"
190Z2ACR	#2	3-1/2"
1150Z2ACR	#2	6"



ACR® stands for Anti-Camout Recess. The ribs on the bit tip engage the fastener recess to reduce stripping, provide increased torque, enhance off-angle drivability, and offer a stick fit that makes screw driving easier.

Pozidriv® and ACR® are registered trademarks of the Phillips Screw Co.



MORTORQ® INSERT BITS		
PART NUMBER	TIP SIZE	LENGTH
125MT00A	00	1"
125MT0A	0	1"
125MT1A	1	1"
125MT2-A*	2	1"



MORTORQ® SUPER INSERT BITS		
PART NUMBER	TIP SIZE	LENGTH
125MTS0	0	1"
125MTS1	1	1"
125MTS2*	2	1"



MORTORQ® INSERT BITS - 5/16" SHANK		
PART NUMBER	TIP SIZE	LENGTH
230MT2A	2	1-1/4"



MORTORQ® SUPER POWER BITS		
PART NUMBER	TIP SIZE	LENGTH
150MTS1	1	2"
190MTS1	1	3-1/2"



* Denotes a bullnose type bit where the tip of the bit has a larger diameter than the hex shank body



MORTORQ® SUPER POWER BITS - 7/16" SHANK		
PART NUMBER	TIP SIZE	LENGTH
350MTS4	4	2"



MORTORQ® SUPER SOCKET BITS - 3/8" SQUARE DRIVE		
PART NUMBER	TIP SIZE	LENGTH
232MTS4SB	4	1-1/4"

MORTORQ® | MORTORQ® SUPER BITS



TORQ-SET® INSERT BITS

PART NUMBER	TIP SIZE	LENGTH
125TS01	1	1"
125TS02	2	1"
125TS03	3	1"
125TS04	4	1"
125TS05	5	1"
125TS06	6	1"
125TS06ACR-R	6	1"
125TS08	8	1"
125TS08ACR-R	8	1"
125TS10	10	1"
125TS10ACR-R	10	1"
125TS416*	1/4"	1"
NEW! 125TS416A	1/4"	1"
125TS416ACR-R*	1/4"	1"



TORQ-SET® INSERT BITS - 5/16" SHANK

PART NUMBER	TIP SIZE	LENGTH
232TS08I	8	1-1/4"
232TS08IACR-R	8	1-1/4"
232TS10I	10	1-1/4"
232TS10IACR-R	10	1-1/4"
232TS416I	1/4"	1-1/4"
232TS416IACR-R	1/4"	1-1/4"
232TS516I	5/16"	1-1/4"
232TS516IACR-R	5/16"	1-1/4"
232TS616I*	3/8"	1-1/4"
232TS616IACR-R*	3/8"	1-1/4"



* Denotes a bullnose type bit where the tip of the bit has a larger diameter than the hex shank body



TORQ-SET® POWER BITS

PART NUMBER	TIP SIZE	LENGTH
132TS00	0	1-1/4"
132TS01	1	1-1/4"
132TS02	2	1-1/4"
132TS03	3	1-1/4"
132TS04	4	1-1/4"
132TS05	5	1-1/4"
132TS06	6	1-1/4"
NEW! 132TS06ACR-R	6	1-1/4"
132TS08	8	1-1/4"
NEW! 132TS08ACR-R	8	1-1/4"
132TS10	10	1-1/4"
NEW! 132TS10ACR-R	10	1-1/4"
132TS416*	1/4"	1-1/4"
NEW! 132TS416ACR-R*	1/4"	1-1/4"
132TS516*	5/16"	1-1/4"
132TS616*	3/8"	1-1/4"
150TS00	0	2"
NEW! 150TS01	1	2"
150TS02	2	2"
150TS03	3	2"
150TS04	4	2"
NEW! 150TS05	5	2"
150TS06	6	2"
150TS08	8	2"
150TS10	10	2"
170TS01	1	2-3/4"
170TS02	2	2-3/4"
NEW! 170TS03	3	2-3/4"
170TS04	4	2-3/4"
170TS05	5	2-3/4"
170TS06	6	2-3/4"
170TS08	8	2-3/4"
170TS10	10	2-3/4"
NEW! 190TS01	1	3-1/2"
190TS02	2	3-1/2"
NEW! 190TS03	3	3-1/2"
190TS04	4	3-1/2"
190TS05	5	3-1/2"
190TS06	6	3-1/2"
190TS08	8	3-1/2"
190TS10	10	3-1/2"
1150TS04	4	6"
NEW! 1150TS06	6	6"
NEW! 1150TS08	8	6"
NEW! 1150TS10	10	6"

Part numbers that end with ACR-R are available with ACR® ribs for removal only



TORQ-SET® POWER BITS - 5/16" SHANK

PART NUMBER	TIP SIZE	LENGTH
232TS08P	8	1-1/4"
NEW! 232TS08PACR-R	8	1-1/4"
232TS10P	10	1-1/4"
NEW! 232TS10PACR-R	10	1-1/4"
232TS416P*	1/4"	1-1/4"
NEW! 232TS416PACR-R*	1/4"	1-1/4"
232TS516P*	5/16"	1-1/4"
NEW! 232TS516PACR-R*	5/16"	1-1/4"
232TS616P*	3/8"	1-1/4"



TRI-WING® INSERT BITS

PART NUMBER	TIP SIZE	LENGTH
125TW01	1	1"
125TW02	2	1"
125TW03	3	1"
125TW04	4	1"
125TW05	5	1"
125TW06*	6	1"
125TW07*	7	1"
NEW! 125TW08*	8	1"



TORQ-SET® POWER BITS - 7/16" SHANK

PART NUMBER	TIP SIZE	LENGTH
332TS416	1/4"	1-1/4"
NEW! 332TS416PACR-R	1/4"	1-1/4"
332TS516	5/16"	1-1/4"
NEW! 332TS516PACR-R	5/16"	1-1/4"
332TS616	3/8"	1-1/4"
332TS716	7/16"	1-1/4"



NEW! TRI-WING INSERT BITS - 5/16" SHANK

PART NUMBER	TIP SIZE	LENGTH
232TW03I	3	1-1/4"
232TW04I	4	1-1/4"
232TW05I	5	1-1/4"
232TW06I	6	1-1/4"
232TW07I	7	1-1/4"



* Denotes a bullnose type bit where the tip of the bit has a larger diameter than the hex shank body



TRI-WING® POWER BITS

PART NUMBER	TIP SIZE	LENGTH
132TW02	2	1-1/4"
132TW03	3	1-1/4"
132TW04	4	1-1/4"
132TW05	5	1-1/4"
132TW06*	6	1-1/4"

Part numbers that end with ACR-R are available with ACR® ribs for removal only

TORQ-SET® and TRI-WING® are registered trademarks of Phillips Screw Co.

TORQ-SET® | TRI-WING® BITS



DOUBLE SQUARE INSERT BITS

PART NUMBER	TIP SIZE	LENGTH
125DS01A	#1	1"
125DS02A	#2	1"
125DS03A	#3	1"



NEW! DOUBLE SQUARE POWER BITS

PART NUMBER	TIP SIZE	LENGTH
150DS02A	#2	2"
170DS02A	#2	2-3/4"
190DS02A	#2	3-1/2"



TRIPLE SQUARE INSERT BITS

PART NUMBER	TIP SIZE	LENGTH
125XZN04	4	1"
125XZN05	5	1"
125XZN06	6	1"
125XZN08	8	1"
125XZN10	10	1"



TRIPLE SQUARE INSERT BITS - 5/16" SHANK

PART NUMBER	TIP SIZE	LENGTH
232XZN04	4	1-1/4"
232XZN05	5	1-1/4"
232XZN06	6	1-1/4"
232XZN08	8	1-1/4"
232XZN10	10	1-1/4"
NEW! 232XZN12	12	1-1/4"
NEW! 232XZN14	14	1-1/4"



TRIPLE SQUARE SOCKET BITS - 1/4" SQUARE DRIVE

PART NUMBER	TIP SIZE	LENGTH
120XZN05SB	5	3/4"
120XZN06SB	6	3/4"
120XZN08SB	8	3/4"
120XZN10SB	10	3/4"
120XZN12SB	12	3/4"



TRIPLE SQUARE SOCKET BITS - 3/8" SQUARE DRIVE

PART NUMBER	TIP SIZE	LENGTH
228XZN05SB	5	1"
228XZN06SB	6	1"
228XZN08SB	8	1"
228XZN10SB	10	1"
228XZN12SB	12	1"
228XZN14SB	14	1"



TRIPLE SQUARE SOCKET BITS - 1/2" SQUARE DRIVE

PART NUMBER	TIP SIZE	LENGTH
338XZN06SB	6	1-1/2"
338XZN08SB	8	1-1/2"
338XZN10SB	10	1-1/2"
338XZN12SB	12	1-1/2"
338XZN14SB	14	1-1/2"

DOUBLE SQUARE | TRIPLE SQUARE BITS



SPANNER INSERT BITS		
PART NUMBER	TIP SIZE	LENGTH
125SP04A	#4	1"
125SP06A	#6	1"
125SP08A	#8	1"
125SP10A	#10	1"
125SP12A	#12	1"
125SP14A	#14	1"



CLUTCH INSERT BITS		
PART NUMBER	TIP SIZE	LENGTH
125CG332A	3/32"	1"
125CG432A	1/8"	1"
125CG532A	5/32"	1"
125CG632A	3/16"	1"
125CG832A	1/4"	1"



SPANNER INSERT BITS - 5/16" SHANK		
PART NUMBER	TIP SIZE	LENGTH
238SP04A	#4	1-1/2"
238SP06A	#6	1-1/2"
238SP08A	#8	1-1/2"
238SP10A	#10	1-1/2"
238SP12A	#12	1-1/2"
238SP14A	#14	1-1/2"



CLUTCH POWER BITS		
PART NUMBER	TIP SIZE	LENGTH
150CG432A	1/8"	2"
150CG532A	5/32"	2"
150CG632A	3/16"	2"
150CG832A	1/4"	2"



HTS SOCKET BITS - 1/4" SQUARE DRIVE		
PART NUMBER	TIP SIZE	LENGTH
125HTS1SB	1	1"
125HTS2SB	2	1"
125HTS3SB	3	1"
125HTS4SB	4	1"



HTS SOCKET BITS - 3/8" SQUARE DRIVE		
PART NUMBER	TIP SIZE	LENGTH
225HTS3SB	3	1"
225HTS4SB	4	1"
232HTS5SB	5	1-1/4"
232HTS6SB	6	1-1/4"

SPANNER | CLUTCH | HTS BITS



**PHILLIPS SQUARE-DRIV ACR®
INSERT BITS**

PART NUMBER	TIP SIZE	LENGTH
NEW! 125PSD12	1-2	1"
125PSD22	2-2	1"
NEW! 125PSD33	3-3	1"



**PHILLIPS SQUARE-DRIV ACR®
POWER BITS**

PART NUMBER	TIP SIZE	LENGTH
150PSD12	1-2	2"
150PSD22	2-2	2"
150PSD33	3-3	2"
170PSD22	2-2	2-3/4"
190PSD22	2-2	3-1/2"
1150PSD22	2-2	6"



**PHILLIPS SQUARE COMBO
INSERT BITS**

PART NUMBER	TIP SIZE	LENGTH
NEW! 125QRV0	#0	1"
125QRV1	#1	1"
125QRV2	#2	1"



**PHILLIPS SQUARE COMBO
POWER BITS**

PART NUMBER	TIP SIZE	LENGTH
NEW! 150QRV1	#1	2"
150QRV2	#2	2"



NEW! FREARSON INSERT BITS

PART NUMBER	TIP SIZE	LENGTH
125FRS	All	1"



NEW! FREARSON POWER BITS

PART NUMBER	TIP SIZE	LENGTH
150FRS	All	2"

PHILLIPS SQUARE-DRIV ACR® | PHILLIPS SQUARE COMBO | FREARSON BITS

PHILLIPS SQUARE-DRIV ACR® is a registered trademark of Phillips Screw Co.



PHILLIPS INSERT BITS

PART NUMBER	TIP SIZE	LENGTH
125P1SS	#1	1"
125P2SS	#2	1"
125P3SS	#3	1"



PHILLIPS POWER BITS

PART NUMBER	TIP SIZE	LENGTH
150P1SS	#1	2"
150P2SS	#2	2"
150P3SS	#3	2"
170P2SS	#2	2-3/4"
190P2SS	#2	3-1/2"
1150P2SS	#2	6"



POZIDRIV® INSERT BITS

PART NUMBER	TIP SIZE	LENGTH
125Z1SS	#1	1"
125Z2SS	#2	1"
125Z3SS	#3	1"



SLOTTED INSERT BITS

PART NUMBER	SCREW SIZE	TIP SIZE (T x D)	LENGTH
125F04SS	3F-4R	.032 x .156	1"
125F05SS	4F-5R	.033 x .182	1"
125F06SS	5F-6R	.036 x .232	1"
125F08SS	6F-8R	.039 x .250	1"
125F10SS	8F-10R	.042 x .281	1"

stainless steel Ideal for environments where corrosion and rust are severe. The high performance Stainless Steel used by Vega provides a superior mix of strength and corrosion resistance.



TORX® INSERT BITS

PART NUMBER	TIP SIZE	LENGTH
125T10SS	10	1"
125T15SS	15	1"
125T20SS	20	1"
125T25SS	25	1"
125T27SS	27	1"
125T30SS	30	1"
125T40SS	40	1"



PHILLIPS SQUARE-DRIV ACR® INSERT BITS

PART NUMBER	TIP SIZE	LENGTH
125PSD22SS	2-2	1"



PHILLIPS SQUARE-DRIV ACR® POWER BITS

PART NUMBER	TIP SIZE	LENGTH
150PSD22SS	2-2	2"



HEX INSERT BITS

PART NUMBER	TIP SIZE	LENGTH
125H0664SS	3/32"	1"
125H0764SS	7/64"	1"
125H0864SS	1/8"	1"
125H0964SS	9/64"	1"
125H1064SS	5/32"	1"
125H1264SS	3/16"	1"
125H1464SS	7/32"	1"
125H1664SS	1/4"	1"

STAINLESS STEEL BITS

TORX® is a registered trademark of Acument Global Technologies, LLC.

PHILLIPS SQUARE-DRIV ACR® and POZIDRIV® are registered trademarks of Phillips Screw Co.



PHILLIPS INSERT BITS

PART NUMBER	TIP SIZE	LENGTH
125P1A-TI	#1	1"
125P2A-TI	#2	1"
125P3A-TI	#3	1"



POZIDRIV® INSERT BITS

PART NUMBER	TIP SIZE	LENGTH
125Z1A-TI	#1	1"
125Z2A-TI	#2	1"
125Z3A-TI	#3	1"



PHILLIPS INSERT BITS - ACR®

PART NUMBER	TIP SIZE	LENGTH
125P1CR-TI	#1	1"
125P2CR-TI	#2	1"
125P3CR-TI	#3	1"



SQUARE INSERT BITS

PART NUMBER	TIP SIZE	LENGTH
125R1A-TI	#1	1"
125R2A-TI	#2	1"
125R3A-TI	#3	1"



PHILLIPS POWER BITS

PART NUMBER	TIP SIZE	LENGTH
150P1A-TI	#1	2"
150P2A-TI	#2	2"
150P3A-TI	#3	2"



NEW! SQUARE POWER BITS

PART NUMBER	TIP SIZE	LENGTH
150R1A-TI	#1	2"
150R2A-TI	#2	2"
150R3A-TI	#3	2"



Ti Titanium Nitride bits have a rough surface creating millions of micro gripping points. The Titanium coating provides an extra hard surface over the gripping points to protect them during use. The increase in roughness grips the entire recess of the screw and reduces camout.



SLOTTED INSERT BITS

PART NUMBER	SCREW SIZE	TIP SIZE (T x D)	LENGTH
125F04A-TI	3F-4R	.032 x .156	1"
125F05A-TI	4F-5R	.033 x .182	1"
125F06A-TI	5F-6R	.036 x .232	1"
125F08A-TI	6F-8R	.039 x .250	1"
125F10A-TI	8F-10R	.042 x .281	1"



NEW! TORQ-SET® INSERT BITS

PART NUMBER	TIP SIZE	LENGTH
125TS06-TI	6	1"
125TS08-TI	8	1"
125TS10-TI	10	1"
125TS416-TI	1/4"	1"

TITANIUM NITRIDE TIPPED BITS

ACR®, TORQ-SET® and POZIDRIV® are registered trademarks of Phillips Screw Co.



PHILLIPS INSERT BITS

PART NUMBER	TIP SIZE	LENGTH
125P1DT	#1	1"
125P2DT	#2	1"
125P3DT	#3	1"



POZIDRIV® INSERT BITS

PART NUMBER	TIP SIZE	LENGTH
125Z1DT	#1	1"
125Z2DT	#2	1"
125Z3DT	#3	1"



SLOTTED INSERT BITS

PART NUMBER	SCREW SIZE	TIP SIZE (T x D)	LENGTH
125F04DT	3F-4R	.032 x .156	1"
125F05DT	4F-5R	.033 x .182	1"
125F06DT	5F-6R	.036 x .232	1"
125F08DT	6F-8R	.039 x .250	1"
125F10DT	8F-10R	.042 x .281	1"



TORX® INSERT BITS

PART NUMBER	TIP SIZE	LENGTH
125T08DT	8	1"
125T10DT	10	1"
125T15DT	15	1"
125T20DT	20	1"
125T25DT	25	1"
125T27DT	27	1"
125T30DT	30	1"
125T40DT	40	1"



NEW! TORQ-SET® INSERT BITS

PART NUMBER	TIP SIZE	LENGTH
125TS06DT	6	1"
125TS08DT	8	1"
125TS10DT	10	1"
125TS416DT	1/4"	1"



 Diamond grit is embedded in the steel substrate and improves screw engagement reducing the risk of damage to the screw recess or camout. This extra hard diamond coating wears less and grips better than a Titanium coating.

DIAMOND TIPPED BITS

TORX® is a registered trademark of Acument Global Technologies, LLC.
 ACR®, TORQ-SET®, and POZIDRIV® are registered trademarks of Phillips Screw Co.

BIT HOLDERS



- Wide variety of bit holders available for different applications
- Hex drive bit holders available in 1/4" and 7/16" drive sizes
- Square drive bit holders available in 1/4", 3/8" and 1/2" drive sizes
- Extended reach bit holders available up to 12"
- Variety of retention options available including Magnetic, C-Ring, Quick-Release, Screw Cap and Set Screw



MAGNETIC BIT HOLDERS

PART NUMBER	LENGTH	ØD
160MH1AD	2-3/8"	.393"
175MH1AD	3"	.393"
1100MH1AD	4"	.393"
1150MH1AD	6"	.393"
1200MH1AD	8"	.393"
1250MH1AD	10"	.393"
1300MH1AD	12"	.393"



1 PC QUICK RELEASE MAGNETIC BIT HOLDERS

PART NUMBER	LENGTH	ØD
150MH1QD	2"	.410"
160MH1QD	2-3/8"	.410"
175MH1QD	3"	.410"
1100MH1QD	4"	.410"
1150MH1QD	6"	.410"
NEW! 1300MH1QD2	12"	.410"



MAGNETIC BIT HOLDERS W/ C-RING

PART NUMBER	OPENING SIZE	LENGTH	ØD
NEW! 151MH1CD2	1/4"	2"	.433"
175MH1CD2	1/4"	3"	.433"
NEW! 175MH2CD2	5/16"	3"	.559"
NEW! 1100MH1CD2	1/4"	4"	.433"
NEW! 1150MH1CD2	1/4"	6"	.433"
NEW! 1200MH1CD2	1/4"	8"	.433"
NEW! 1250MH1CD2	1/4"	10"	.433"
NEW! 1300MH1CD2	1/4"	12"	.433"



MAGNETIC BIT HOLDERS W/ SCREW CAP & O-RING

PART NUMBER	LENGTH	ØD
160MH1CC	2-3/8"	.433"
175MH1CC	3"	.433"
NEW! 1150MH1CC	6"	.433"



1 PC STAINLESS STEEL MAGNETIC BIT HOLDERS W/ C-RING

PART NUMBER	LENGTH	ØD
154MH1CD	2-1/8"	.433"
159MH1CD	2-3/8"	.433"
175MH1CD	3"	.433"
1100MH1CD	4"	.433"
1150MH1CD	6"	.433"
1200MH1CD	8"	.433"
1250MH1CD	10"	.433"
1300MH1CD	12"	.433"



MAGNETIC BIT HOLDERS W/ SCREW CAP

PART NUMBER	LENGTH	ØD
160MH1CM	2-3/8"	.551"

External magnet to hold fasteners securely to bit



MAGNETIC BIT HOLDERS W/ FINDER SLEEVE

PART NUMBER	LENGTH	ØD
175MH1DL	3-1/8"	.470"
1120MH1DL	4"	.470"

Sleeve extends to keep screws straight while driving



MAGNETIC BIT HOLDERS W/ REDUCED BODY

PART NUMBER	LENGTH	ØD
173MH1CD2	2-7/8"	.433"

Extended Reach Options Available up to 12"





SDS DRIVE - QUICK RELEASE MAGNETIC BIT HOLDERS

PART NUMBER	LENGTH	ØD
10M80SDS1QF	3-3/16"	.393"



NON-MAGNETIC BIT HOLDERS W/ C-RING

PART NUMBER	OPENING SIZE	HEX SHANK	LENGTH	ØD
NEW! 154NH1CA	1/4"	1/4"	2-1/8"	.433"
365NH1CA	1/4"	7/16"	2-1/2"	.563"
365NH2CA	5/16"	7/16"	2-1/2"	.563"



SQUARE DRIVE QUICK RELEASE BIT HOLDERS

PART NUMBER	OPENING SIZE	SQUARE DRIVE	LENGTH
NEW! 1HQ416SK	1/4"	1/4"	1-1/2"
NEW! 2HQ416SK	1/4"	3/8"	2"
2HQ716SK	7/16"	3/8"	2"
NEW! 3HQ416SK	1/4"	1/2"	2-5/32"
3HQ716SK	7/16"	1/2"	2-5/32"



SQUARE DRIVE BIT HOLDERS W/ SET SCREW

PART NUMBER	OPENING SIZE	SQUARE DRIVE	LENGTH
NEW! 1HS416SK	1/4"	1/4"	1-1/4"
NEW! 2HS416SK	1/4"	3/8"	1-1/2"
2HS716SK	7/16"	3/8"	1-1/2"
NEW! 3HS416SK	1/4"	1/2"	1-1/2"
3HS716SK	7/16"	1/2"	1-1/2"

Combine with power bits to form socket bit assemblies



SQUARE DRIVE BIT HOLDERS W/ C-RING

PART NUMBER	OPENING SIZE	SQUARE DRIVE	LENGTH
1HC416SK	1/4"	1/4"	1"
2HC416SK	1/4"	3/8"	1-3/8"
2HC516SK	5/16"	3/8"	1-3/8"
3HC416SK	1/4"	1/2"	1-3/4"
3HC516SK	5/16"	1/2"	1-3/4"



MAGNETIC SQUARE DRIVE BIT HOLDERS W/ C-RING

PART NUMBER	OPENING SIZE	SQUARE DRIVE	LENGTH
M1HC416SK2	1/4"	1/4"	2-5/8"
M2HC416SK2	1/4"	3/8"	2-21/32"
M2HC516SK2	5/16"	3/8"	2-3/4"
M3HC416SK2	1/4"	1/2"	2-21/32"
M3HC516SK2	5/16"	1/2"	2-3/4"

BIT HOLDERS | SQUARE DRIVE BIT HOLDERS

Socket Bit Assembly Example



350H1064A

3HS716SK



- All nutsetters are precision forged from S2 modified shock resistant steel
- Comprehensive offering of Inch, Metric, Lobular, Magnetic, Non-Magnetic and SDS Drive nutsetters available
- Lobular design reduces stripping damage of hex head fasteners by driving the fastener on the sides instead of on the corners
- Extended reach nutsetters available up to 12"
- Broad offering of specialty drivers available for driving hanger bolts, eye bolts, screw hooks, and eye lags



NEW! MAGNETIC INSERT NUTSETTERS

PART NUMBER	SIZE	LENGTH
132MN416	1/4"	1-1/4"
132MN516	5/16"	1-1/4"
132MN616	3/8"	1-1/4"



LOBULAR MAGNETIC NUTSETTERS

PART NUMBER	SIZE	LENGTH
145MN416R	1/4"	1-3/4"
145MN516R	5/16"	1-3/4"
145MN616R	3/8"	1-3/4"
145MN716R	7/16"	1-3/4"
145MN816R	1/2"	1-3/4"
165MN416R	1/4"	2-9/16"
165MN516R	5/16"	2-9/16"
165MN616R	3/8"	2-9/16"
165MN716R	7/16"	2-9/16"
165MN816R	1/2"	2-9/16"



LOBULAR DESIGN

Rounded shape design in the opening that reduces stripping damage of hex head fasteners by driving the fastener on the sides instead of on the corners.

INCH



MAGNETIC NUTSETTERS

PART NUMBER	SIZE	LENGTH
145MN416	1/4"	1-3/4"
NEW! 145MN416-TH	1/4"	1-3/4"
145MN516	5/16"	1-3/4"
NEW! 145MN516T	5/16"	1-3/4"
145MN616	3/8"	1-3/4"
145MN716	7/16"	1-3/4"
145MN816	1/2"	1-3/4"
145MN916	9/16"	1-3/4"
151MN416T	1/4"	2"
165MN416	1/4"	2-9/16"
NEW! 165MN416-TH	1/4"	2-9/16"
165MN516	5/16"	2-9/16"
165MN616	3/8"	2-9/16"
165MN716	7/16"	2-9/16"
165MN816	1/2"	2-9/16"
165MN916	9/16"	2-9/16"
1100MN416S	1/4"	4"
1100MN516S	5/16"	4"
1100MN616S	3/8"	4"
1100MN716S	7/16"	4"
1150MN416S	1/4"	6"
1150MN516S	5/16"	6"
1150MN616S	3/8"	6"
1150MN716S	7/16"	6"
1200MN416	1/4"	8"
1200MN516	5/16"	8"
1200MN616	3/8"	8"
1250MN416	1/4"	10"
1250MN516	5/16"	10"
1250MN616	3/8"	10"
1300MN416	1/4"	12"
1300MN516	5/16"	12"
1300MN616	3/8"	12"

T denotes tapered design
TH denotes thin wall design



NON-MAGNETIC NUTSETTERS

PART NUMBER	SIZE	LENGTH
165NN416	1/4"	2-9/16"
165NN516	5/16"	2-9/16"
165NN616	3/8"	2-9/16"
165NN716	7/16"	2-9/16"



NON-MAGNETIC NUTSETTERS WITH C-RING

PART NUMBER	SIZE	LENGTH
145NN416C	1/4"	1-3/4"
145NN516C	5/16"	1-3/4"
145NN616C	3/8"	1-3/4"
165NN416C	1/4"	2-9/16"
165NN516C	5/16"	2-9/16"
165NN616C	3/8"	2-9/16"

For use with stainless screws



SDS DRIVE MAGNETIC NUTSETTERS

PART NUMBER	SIZE	LENGTH
165MN416SDS	1/4"	2-9/16"
165MN516SDS	5/16"	2-9/16"
165MN616SDS	3/8"	2-9/16"
165MN716SDS	7/16"	2-9/16"
165MN816SDS	1/2"	2-9/16"
165MN916SDS	9/16"	2-9/16"



MAGNETIC NUTSETTERS

PART NUMBER	SIZE	LENGTH
145MN055M	5.5mm	1-3/4"
145MN06M	6mm	1-3/4"
145MN07M	7mm	1-3/4"
145MN08M	8mm	1-3/4"
145MN10M	10mm	1-3/4"
145MN12M	12mm	1-3/4"
145MN13M	13mm	1-3/4"
165MN055M	5.5mm	2-9/16"
165MN06M	6mm	2-9/16"
165MN07M	7mm	2-9/16"
165MN08M	8mm	2-9/16"
165MN10M	10mm	2-9/16"
165MN12M	12mm	2-9/16"
165MN13M	13mm	2-9/16"
NEW! 1100MN08M	8mm	4"
NEW! 1100MN10M	10mm	4"
NEW! 1100MN12M	12mm	4"
NEW! 1150MN08M	8mm	6"
NEW! 1150MN10M	10mm	6"
NEW! 1150MN12M	12mm	6"



HANGER BOLT DRIVERS

PART NUMBER	SIZE	LENGTH
145HB416	1/4"-20	1-3/4"
145HB516	5/16"-18	1-3/4"
145HB616	3/8"-16	1-3/4"
165HB416	1/4"-20	2-9/16"
165HB516	5/16"-18	2-9/16"
165HB616	3/8"-16	2-9/16"
165HB1024	10-24	2-9/16"
165HBM6	M6	2-9/16"
165HBM8	M8	2-9/16"



EYE LAG SCREW DRIVER

PART NUMBER	SIZE	LENGTH
168ELSD	7/16"	2-11/16"



Y ADAPTER

PART NUMBER	SIZE	LENGTH
Y-ADAPTER	13/16"	1"

Used to drive hook screws and eye bolts

Extended Reach Options Available up to 12"



ADAPTERS & EXTENSIONS



- Adapters and extensions consistently meet the challenges of even the most demanding industrial & construction applications
- All adapters and extensions are made from S2 modified shock resistant steel
- Extended reach options available up to 12"
- Available in 1/4" and 7/16" hex drives with 1/4", 3/8" and 1/2" male square ends



1/4" SQUARE - INSERT ADAPTER

PART NUMBER	MALE SQUARE	LENGTH	LOCK TYPE
125ADB14	1/4"	1"	Ball



1/4" SQUARE - ADAPTERS & EXTENSIONS

PART NUMBER	MALE SQUARE	LENGTH	LOCK TYPE
150ADB14	1/4"	2"	Ball
175ADB14	1/4"	3"	Ball
1100ADB14	1/4"	4"	Ball
1150ADB14	1/4"	6"	Ball
150ADP14	1/4"	2"	Pin
175ADP14	1/4"	3"	Pin
1100ADP14	1/4"	4"	Pin
1125ADP14	1/4"	5"	Pin
1150ADP14	1/4"	6"	Pin
1200ADP14	1/4"	8"	Pin
NEW! 1250ADP14	1/4"	10"	Pin
NEW! 1300ADP14	1/4"	12"	Pin



1/4" SQUARE - QUICK RELEASE ADAPTERS & EXTENSIONS

PART NUMBER	MALE SQUARE	LENGTH	LOCK TYPE
NEW! 160QADB14	1/4"	2-3/8"	Ball
175QADB14	1/4"	3"	Ball
1150QADB14	1/4"	6"	Ball



Ball lock provides quick change outs

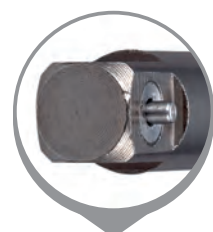

Pin lock provides extra security and safety



3/8" SQUARE - ADAPTERS & EXTENSIONS

PART NUMBER	MALE SQUARE	LENGTH	LOCK TYPE
150ADB38	3/8"	2"	Ball
175ADB38	3/8"	3"	Ball
1100ADB38	3/8"	4"	Ball
1150ADB38	3/8"	6"	Ball
150ADP38	3/8"	2"	Pin
175ADP38	3/8"	3"	Pin
1100ADP38	3/8"	4"	Pin
1125ADP38	3/8"	5"	Pin
1150ADP38	3/8"	6"	Pin
1200ADP38	3/8"	8"	Pin
NEW! 1250ADP38	3/8"	10"	Pin
NEW! 1300ADP38	3/8"	12"	Pin



1/2" SQUARE - ADAPTERS & EXTENSIONS

PART NUMBER	MALE SQUARE	LENGTH	LOCK TYPE
150ADB12	1/2"	2"	Ball
150ADP12	1/2"	2"	Pin



7/16" SHANK - ADAPTERS & EXTENSIONS

PART NUMBER	MALE SQUARE	LENGTH	LOCK TYPE
375ADP14	1/4"	3"	Pin
375ADP38	3/8"	3"	Pin
375ADP12	1/2"	3"	Pin

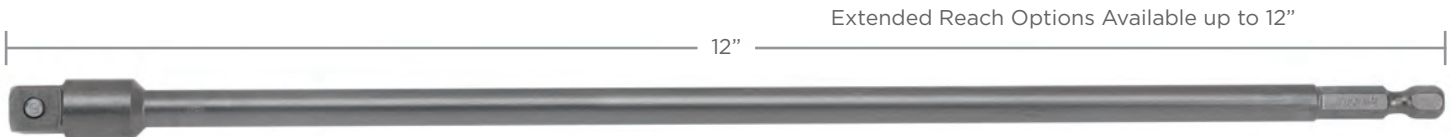

Extended Reach Options Available up to 12"

ADAPTERS & EXTENSIONS

BIT SETS



- Bit sets consistently meet the needs of the professional user's most demanding applications
- All bits are made from S2 modified shock resistant steel
- Bit tips are CNC machined for excellent fit in the fastener recess and reduced camout
- Variety of set options available, from compact low piece count sets to high piece count master sets to cover any application or fastener drive type

6 PC DRIVER BIT & NUTSETTER SET

6 PCS

PART NUMBER	PIECE COUNT	CASE QUANTITY
V4N2B	6	20
CONTENTS:		
PHILLIPS		2
SLOTTED		6-8
NUTSETTERS		1/4", 5/16", 3/8", 7/16"



FEATURES

- Common power bits and magnetic nutsetters
- Compact storage bar

25 PCS



25 PC DRIVER BIT SET

PART NUMBER	PIECE COUNT	CASE QUANTITY
VT-25B	25	10
CONTENTS:		
PHILLIPS		1, 2, 3
TORX		8, 9, 10, 15, 20, 25, 27, 30, 40
HEX		1/16", 5/64", 7/64", 9/64", 3/16", 1/4"
SLOTTED		4-5, 6-8, 8-10
SQUARE		1, 2, 3
		Quick Release Bit Holder

25 PC SECURITY DRIVER BIT SET

PART NUMBER	PIECE COUNT	CASE QUANTITY
VT-25A	25	10
CONTENTS:		
PHILLIPS TAMPER		1, 2, 3
TORX TAMPER		8, 9, 10, 15, 20, 25, 27, 30, 40
HEX TAMPER		1/16", 5/64", 7/64", 9/64", 3/16", 1/4"
SLOTTED		4-5, 6-8, 8-10
SQUARE		1, 2, 3
		Quick Release Bit Holder

FEATURES

- Compact storage case with convenient belt clip design

If full case quantity ordered, sets ship in color countertop display box



TORX® is a registered trademark of Acument Global Technologies, LLC.

32 PCS



32 PC DRIVER BIT SET

PART NUMBER	PIECE COUNT	CASE QUANTITY
V32-1P	32	12
CONTENTS:		
PHILLIPS		0, 1, 2, 2R, 3
TORX®		10, 15, 20, 25, 27, 30, 40
SLOTTED		3-4, 4-5, 6-8, 8-10, 10-12
HEX		5/64", 3/32", 7/64", 1/8", 9/64" 5/32", 3/16", 7/32", 1/4", 5/16"
SQUARE		1, 2, 3
1/4" SQ DR SOCKET		1/4"
		Quick Release Bit Holder

32 PC SECURITY DRIVER BIT SET

PART NUMBER	PIECE COUNT	CASE QUANTITY
V32-1TP	32	12
CONTENTS:		
PHILLIPS TAMPER		2, 3
TORX® TAMPER		5, 6, 7, 8, 9, 10, 15, 20, 25, 27, 30, 40
HEX TAMPER		5/64", 3/32", 7/64", 1/8", 9/64" 5/32", 3/16", 7/32", 1/4", 5/16"
SPANNER		4, 6, 8, 10, 12, 14
1/4" SQ DR SOCKET		1/4"
		Quick Release Bit Holder

FEATURES

- Compact storage case with convenient belt clip design

DRIVER BIT SETS

33 PC DRIVER BIT & SOCKET SET

PART NUMBER	PIECE COUNT	CASE QUANTITY
V33-1SB	33	10
CONTENTS:		
PHILLIPS		1, 2, 3
TORX®		10, 15, 20, 25, 30, 40
SLOTTED		4-5, 5-6, 6-8, 8-10, 10-12
HEX		5/64", 3/32", 1/8", 9/64" 5/32", 3/16"
SQUARE		1, 2, 3
SOCKET ADAPTER		1/4" x 1/4"
1/4" SQ DR SOCKETS		3/16", 7/32", 1/4", 9/32", 5/16" 3/8", 7/16", 1/2"
		Quick Release Bit Holder

33 PCS



FEATURES

- Common bit and socket sizes
- Heavy duty storage case



TORX® is a registered trademark of Acument Global Technologies, LLC.

If full case quantity ordered, sets ship in color countertop display box

50 PCS





50 PC INDUSTRIAL DRIVER BIT SET

PART NUMBER	PIECE COUNT	CASE QUANTITY
V50-1P	50	10
CONTENTS:		
PHILLIPS	+	0, 1, 2, 3 ACR® 0, 1, 2, 3
POZIDRIV®	⊕	0, 1, 2, 3
TORX®	⊛	5, 6, 7, 8, 9, 10, 15, 20, 25, 27, 30, 40
SLOTTED	◐	3-4, 4-5, 5-6, 6-8, 8-10 10-12, 12-14, 14-16
HEX	⊙	1/16", 5/64", 3/32", 7/64", 1/8", 9/64" 5/32", 3/16", 7/32", 1/4", 5/16"
SQUARE	⊠	0, 1, 2, 3
SOCKET ADAPTER	⊡	1/4" x 1/4"
1/4" SQ DR SOCKET	⊚	1/4"
		Quick Release Bit Holder

FEATURES

- Designed for industrial and professional construction applications
- Heavy duty storage case

100 PC MASTER DRIVER BIT SET

PART NUMBER	PIECE COUNT	CASE QUANTITY
VHS100A	100	6
CONTENTS:		
PHILLIPS	+	0, 1, 2R, 2, 3, 4 ACR® 1, 2R, 2, 3
POZIDRIV®	⊕	0, 1, 2, 3, 4 ACR® 1, 2, 3
SQUARE	⊠	0, 1, 2, 3, 4, 5
TORX®	⊛	6, 7, 8, 9, 10, 15, 20, 25, 27, 30, 40, 45, 50
CLUTCH	⊖	5/32", 3/16", 1/4"
HEX	⊙	5/64", 3/32", 7/64", 1/8", 9/64" 5/32", 3/16", 7/32", 1/4", 5/16"
SLOTTED	◐	3-4, 4-5, 5-6, 6-8, 8-10, 10-12, 12-14
TRIPLE SQUARE	⊚	4, 5, 6, 8
TORQ-SET®	⊕	8, 10, 1/4, 5/16, 3/8
SPANNER	⊗	4, 6, 8, 10, 12
TORX® TAMPER	⊛	6, 7, 8, 9, 10, 15, 20, 25, 27, 30, 40
HEX TAMPER	⊙	5/64", 3/32", 7/64", 1/8", 9/64" 5/32", 3/16", 7/32", 1/4", 5/16"
TRI-WING®	⊚	1, 2, 3, 4, 5
SOCKET ADAPTERS	⊡	1/4" x 1", 1/4" x 2"
		Y-Adapter
1/4" SQ DR BIT HOLDER	⊚	1/4"
		Magnetic Bit Holder

100 PCS



FEATURES

- Comprehensive set of common and hard to find bits
- Designed for industrial and professional construction applications

If full case quantity ordered, sets ship in color countertop display box

DRIVER BIT SETS

27 PC INDUSTRIAL BIT & HAND DRIVER SET

27 PCS

NEW!

PART NUMBER	PIECE COUNT	CASE QUANTITY
V27-BRH	27	4
CONTENTS:		
PHILLIPS	+	1, 2,
SLOTTED	⊖	3/16", 1/4", 3/8"
HEX (INCH)	⊙	0.05", 1/16", 5/64", 3/32", 7/64" 1/8", 9/64", 5/32", 3/16", 7/32", 1/4"
HEX (METRIC)	⊙	1.5, 2, 2.5, 3, 4, 5, 6
	⊙	1/4" Ratcheting Bit Wrench
	⊙	Magnetic Bit Holder 1/4" x 4"
	⊙	Industrial Grade Screwdriver



FEATURES

- Bit holder functions as extension for screwdriver and adapter for power tool use
- Ratcheting bit wrench has compact design for limited space applications

DRIVER BIT SETS

31 PCS



31 PC INDUSTRIAL DRIVER BIT & SOCKET SET

PART NUMBER	PIECE COUNT	CASE QUANTITY
VSM31	31	10
CONTENTS:		
PHILLIPS	+	1, 2, 3
SQUARE	⊠	1, 2, 3
SLOTTED	⊖	4-5, 6-8, 8-10
HEX	⊙	9/64", 5/32", 3/16", 7/32", 1/4", 5/16"
TORX®	⊕	8, 10, 15, 20, 25, 27, 30, 40
SOCKET ADAPTER	⊙	1/4" x 1/4"
1/4" SQ DR SOCKET	⊙	1/4", 5/16", 3/8", 7/16", 1/2"
	⊙	Magnetic Bit Holder
	⊙	Magnetic Stubby Bit Ratchet

31 PC INDUSTRIAL SECURITY DRIVER BIT & SOCKET SET

PART NUMBER	PIECE COUNT	CASE QUANTITY
VSMT31	31	10
CONTENTS:		
PHILLIPS TAMPER	+	1, 2, 3
TORX® TAMPER	⊕	8, 10, 15, 20, 25, 27, 30, 40
HEX TAMPER	⊙	9/64", 5/32", 3/16", 7/32", 1/4", 5/16"
SPANNER	⊙	6, 8, 10
TRIPLE SQUARE	⊙	4, 5, 6
SOCKET ADAPTER	⊙	1/4" x 1/4"
1/4" SQ DR SOCKET	⊙	1/4", 5/16", 3/8", 7/16", 1/2"
	⊙	Magnetic Bit Holder
	⊙	Magnetic Stubby Bit Ratchet

FEATURES

- Industrial grade reversible bit ratchet
- Heavy duty storage case



If full case quantity ordered, sets ship in color countertop display box

TORX® is a registered trademark of Acument Global Technologies, LLC. POZIDRIV®, ACR®, PHILLIPS SQUARE-DRIV®, TORQ-SET®, and TRI-WING® are trademarks of the Phillips Screw Company.

39 PC INDUSTRIAL BIT, SOCKET & HAND DRIVER SET

39 PCS



PART NUMBER	PIECE COUNT	CASE QUANTITY
V39	39	4
CONTENTS:		
PHILLIPS	+	1, 2, 3
SQUARE	□	1, 2, 3
SLOTTED	—	3-4, 5-6, 6-8
HEX	⊙	5/64", 3/32", 7/64" 9/64", 3/16", 1/4"
TORX®	⊕	10, 15, 20, 25, 27, 30, 40
PHILLIPS SQUARE-DRIV®	⊕	2-2
SPANNER	⊗	6, 8, 10
SOCKET ADAPTER	□	1/4" x 1/4"
1/4" SQ DR SOCKETS	⊙	3/16", 7/32", 1/4", 9/32", 5/16" 3/8", 7/16", 1/2", 9/16"
		Y-Adapter
		1/4" Sq Dr Sliding T-Bar
		Quick Release Screwdriver





FEATURES

- Includes industrial grade screwdriver with quick release function
- Heavy duty metal storage case

53 PC INDUSTRIAL BIT & HAND DRIVER SET

53 PCS



PART NUMBER	PIECE COUNT	CASE QUANTITY
VSH53A	53	4
CONTENTS:		
PHILLIPS	+	1, 2, 3
SQUARE	□	1, 2, 3
TORX®	⊕	8, 10, 15, 20, 25, 27, 30, 40
TORX® TAMPER	⊕	8, 10, 15, 20, 25, 27, 30, 40
HEX TAMPER	⊙	7/64", 1/8", 5/32", 3/16" 7/32", 1/4", 5/16"
SPANNER	⊗	4, 6, 8, 10, 12
TRI-WING®	⊕	2, 3, 4, 5
TORQ-SET®	⊕	6, 8, 10, 1/4
CLUTCH	⊕	5/32", 3/16", 1/4"
TRIPLE SQUARE	⊕	5, 6, 8
SOCKET ADAPTER	□	1/4" x 1/4"
1/4" SQ DR SOCKET	⊙	1/4"
		Y-Adapter
		Quick Release Bit Holder
		Quick Release Screwdriver

FEATURES

- Includes industrial grade screwdriver with quick release

If full case quantity ordered, sets ship in color countertop display box

TORX® is a registered trademark of Acument Global Technologies, LLC. POZIDRIV®, ACR®, PHILLIPS SQUARE-DRIV®, TORQ-SET®, and TRI-WING® are trademarks of the Phillips Screw Company.

DRIVER BIT SETS

IMPACT SOCKETS



- Comprehensive offering for industrial MRO and professional construction users
- The corners of our hex and square openings have a radius for stress relief providing for more torque while reducing fastener rounding
- Choose from 6pt, 12pt and TORX drive configurations in standard or long lengths
- All magnetic sockets feature industrial strength magnets and our spring-loaded magnets adjust for variable depth applications
- Extended reach adapters and extensions available up to 12"
- Large selection of clip rail sets in all square drive sizes and configurations

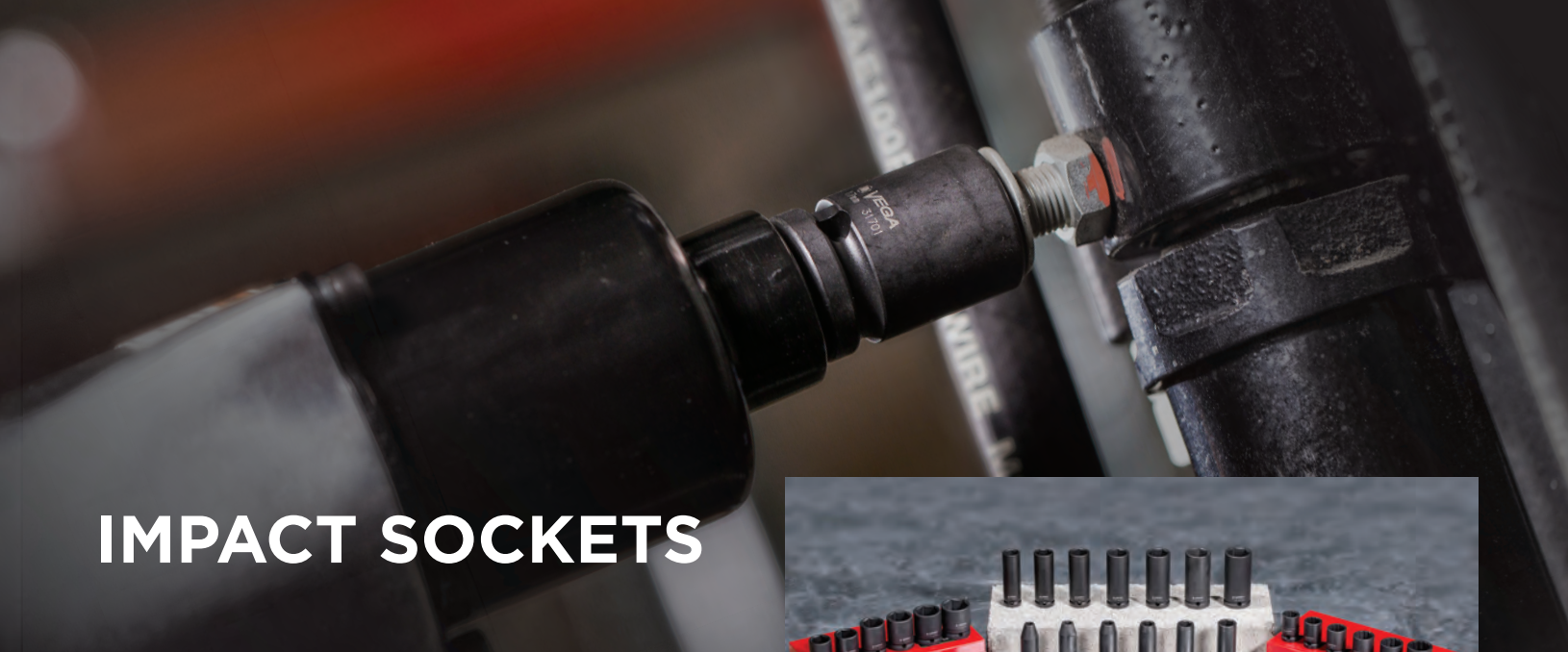

IMPACT SOCKETS



Vega offers a superior lineup of impact sockets for industrial MRO and professional construction users

All of Vega's 1/4" and 3/8" impact sockets under 5/8" in size are uniquely made from S2 modified steel. The most durable tool steel for the repetitive impact put on sockets by today's power tools.

1/2" sockets are made from a high grade 4140 alloy steel which allows for greater flex at higher torque levels.

Vega's new line of impact sockets includes a large selection of clip rail sets in all square drive sizes and configurations.

Square Drive Sizes



Working Configurations



6 Pt 12 Pt TORX



Radius corners on hex and square openings for stress relief providing for more torque while reducing fastener rounding



Industrial strength magnets offered in both fixed and spring depth-adjusting configurations



Thin wall sockets designed for limited clearance applications



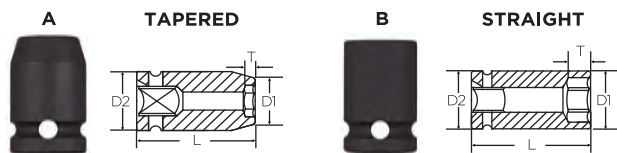

6 PT & 12 PT							
Standard Length							
PART NUMBER 6pt	PART NUMBER 12pt	SIZE (Inch)	D1 (Inch)	D2 (Inch)	T (Inch)	L (Inch)	STYLE
15321	15321-D	5/32	0.30	0.51	0.15	1.0	A
13161	13161-D	3/16	0.32	0.51	0.15	1.0	A
17321	17321-D	7/32	0.36	0.51	0.17	1.0	A
10141	10141-D	1/4	0.42	0.51	0.17	1.0	A
19321	19321-D	9/32	0.46	0.51	0.17	1.0	A
15161	15161-D	5/16	0.46	0.51	0.17	1.0	A
10381	10381-D	3/8	0.58	0.58	0.26	1.0	B
17161	17161-D	7/16	0.66	0.66	0.26	1.0	B
10121	10121-D	1/2	0.74	0.74	0.32	1.0	B
19161	19161-D	9/16	0.81	0.81	0.32	1.0	B
10581	10581-D	5/8	0.88	0.88	0.32	1.0	B

6 PT & 12 PT MAGNETIC							
Standard Length							
PART NUMBER 6pt	PART NUMBER 12pt	SIZE (Inch)	D1 (Inch)	D2 (Inch)	T (Inch)	L (Inch)	STYLE
M15321	M15321-D	5/32	0.30	0.51	0.15	1.0	A
M13161	M13161-D	3/16	0.32	0.51	0.15	1.0	A
M17321	M17321-D	7/32	0.36	0.51	0.17	1.0	A
M10141	M10141-D	1/4	0.42	0.51	0.17	1.0	A
M19321	M19321-D	9/32	0.46	0.51	0.17	1.0	A
M15161	M15161-D	5/16	0.46	0.51	0.17	1.0	A
M10381	M10381-D	3/8	0.58	0.58	0.26	1.0	B
M17161	M17161-D	7/16	0.66	0.66	0.26	1.0	B
M10121	M10121-D	1/2	0.74	0.74	0.32	1.0	B
M19161	M19161-D	9/16	0.81	0.81	0.32	1.0	B

6 PT & 12 PT							
Long Length							
PART NUMBER 6pt	PART NUMBER 12pt	SIZE (Inch)	D1 (Inch)	D2 (Inch)	T (Inch)	L (Inch)	STYLE
15322	15322-D	5/32	0.30	0.51	0.15	2.0	A
13162	13162-D	3/16	0.32	0.51	0.15	2.0	A
17322	17322-D	7/32	0.36	0.51	0.17	2.0	A
10142	10142-D	1/4	0.42	0.51	0.17	2.0	A
19322	19322-D	9/32	0.46	0.51	0.17	2.0	A
15162	15162-D	5/16	0.46	0.51	0.17	2.0	A
10382	10382-D	3/8	0.58	0.58	0.26	2.0	B
17162	17162-D	7/16	0.66	0.66	0.26	2.0	B
10122	10122-D	1/2	0.74	0.74	0.32	2.0	B
19162	19162-D	9/16	0.81	0.81	0.32	2.0	B

6 PT FIXED & SPRING LOADED MAGNETIC							
Long Length							
PART NUMBER Fixed	PART NUMBER Spring Loaded	SIZE (Inch)	D1 (Inch)	D2 (Inch)	T (Inch)	L (Inch)	STYLE
M15322	MSP15322	5/32	0.30	0.51	0.15	2.0	A
M13162	MSP13162	3/16	0.32	0.51	0.15	2.0	A
M17322	MSP17322	7/32	0.36	0.51	0.17	2.0	A
M10142	MSP10142	1/4	0.42	0.51	0.17	2.0	A
M19322	MSP19322	9/32	0.46	0.51	0.17	2.0	A
M15162	MSP15162	5/16	0.46	0.51	0.17	2.0	A
M111322	MSP111322	11/32	0.51	0.51	0.21	2.0	B
M10382	MSP10382	3/8	0.58	0.58	0.26	2.0	B
M17162	MSP17162	7/16	0.66	0.66	0.26	2.0	B
M10122	MSP10122	1/2	0.74	0.74	0.32	2.0	B
M19162	MSP19162	9/16	0.81	0.81	0.32	2.0	B
M10582	MSP10582	5/8	0.88	0.88	0.42	2.0	B

6 PT SHEET METAL							
Standard Length							
PART NUMBER 6pt	PART NUMBER Magnetic	SIZE (Inch)	D1 (Inch)	D2 (Inch)	T (Inch)	L (Inch)	STYLE
S13161	MS13161	3/16	0.32	0.51	0.08	1.0	A
S17321	MS17321	7/32	0.36	0.51	0.08	1.0	A
S10141	MS10141	1/4	0.42	0.51	0.08	1.0	A
S15161	MS15161	5/16	0.49	0.51	0.11	1.0	A
S10381	MS10381	3/8	0.58	0.58	0.14	1.0	B
S17161	MS17161	7/16	0.66	0.66	0.16	1.0	B
S10121	MS10121	1/2	0.74	0.74	0.17	1.0	B

6 PT MAGNETIC THIN WALL							
Standard Length							
PART NUMBER 6pt	SIZE (Inch)	D1 (Inch)	D2 (Inch)	T (Inch)	L (Inch)	STYLE	
M10141-T	1/4	0.37	0.37	0.19	0.9	B	
M15161-T	5/16	0.44	0.44	0.23	0.9	B	

BOLD part numbers are available for fast delivery.

Comprehensive offering 1/4" square drive impact socket sets available on page 69.

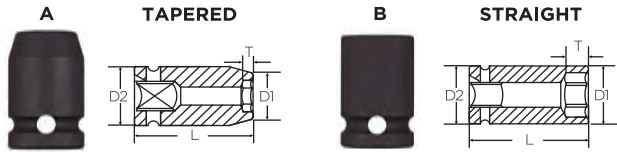

6 PT & 12 PT
Standard Length

PART NUMBER 6pt	PART NUMBER 12pt	SIZE (mm)	D1 (mm)	D2 (mm)	T (mm)	L (mm)	STYLE
10401	10401-D	4	7.8	13.0	3.1	25.0	A
10501	10501-D	5	9.1	13.0	3.8	25.0	A
10551	10551-D	5.5	9.7	13.0	3.8	25.0	A
10601	10601-D	6	10.3	13.0	4.0	25.0	A
10701	10701-D	7	11.6	13.0	4.5	25.0	A
10801	10801-D	8	12.8	13.0	4.5	25.0	A
10901	10901-D	9	14.1	14.1	5.0	25.0	B
11001	11001-D	10	15.6	15.6	5.6	25.0	B
11101	11101-D	11	16.6	16.6	6.5	25.0	B
11201	11201-D	12	17.8	17.8	7.5	25.0	B
11301	11301-D	13	19.1	19.1	8.0	25.0	B
11401	11401-D	14	20.7	20.7	9.0	25.0	B
11501	11501-D	15	21.6	21.6	9.0	25.0	B

6 PT & 12 PT MAGNETIC
Standard Length

PART NUMBER 6pt	PART NUMBER 12pt	SIZE (mm)	D1 (mm)	D2 (mm)	T (mm)	L (mm)	STYLE
M10501	M10501-D	5	9.1	13.0	3.8	25.0	A
M10551	M10551-D	5.5	9.7	13.0	3.8	25.0	A
M10601	M10601-D	6	10.3	13.0	4.0	25.0	A
M10701	M10701-D	7	11.6	13.0	4.5	25.0	A
M10801	M10801-D	8	12.8	13.0	4.5	25.0	A
M10901	M10901-D	9	14.1	14.1	5.0	25.0	B
M11001	M11001-D	10	15.6	15.6	5.6	25.0	B
M11101	M11101-D	11	16.6	16.6	6.5	25.0	B
M11201	M11201-D	12	17.8	17.8	7.5	25.0	B
M11301	M11301-D	13	19.1	19.1	8.0	25.0	B
M11401	M11401-D	14	20.7	20.7	9.0	25.0	B

6 PT & 12 PT
Long Length

PART NUMBER 6pt	PART NUMBER 12pt	SIZE (mm)	D1 (mm)	D2 (mm)	T (mm)	L (mm)	STYLE
10502	10502-D	5	9.1	13.0	3.8	50.0	A
10552	10552-D	5.5	9.7	13.0	3.8	50.0	A
10602	10602-D	6	10.3	13.0	4.0	50.0	A
10702	10702-D	7	11.6	13.0	4.5	50.0	A
10802	10802-D	8	12.8	13.0	4.5	50.0	A
10902	10902-D	9	14.1	14.1	5.0	50.0	B
11002	11002-D	10	15.6	15.6	5.6	50.0	B
11102	11102-D	11	16.6	16.6	6.5	50.0	B
11202	11202-D	12	17.8	17.8	7.5	50.0	B
11302	11302-D	13	19.1	19.1	8.0	50.0	B
11402	11402-D	14	20.7	20.7	9.0	50.0	B

6 PT FIXED & SPRING LOADED MAGNETIC
Long Length

PART NUMBER Fixed	PART NUMBER Spring Loaded	SIZE (mm)	D1 (mm)	D2 (mm)	T (mm)	L (mm)	STYLE
M10602	MSP10602	6	10.3	13.0	4.0	50.0	A
M10702	MSP10702	7	11.6	13.0	4.5	50.0	A
M10802	MSP10802	8	12.8	13.0	4.5	50.0	A
M10902	MSP10902	9	14.1	14.1	5.0	50.0	B
M11002	MSP11002	10	15.6	15.6	5.6	50.0	B
M11102	MSP11102	11	16.6	16.6	6.5	50.0	B
M11202	MSP11202	12	17.8	17.8	7.5	50.0	B
M11302	MSP11302	13	19.1	19.1	8.0	50.0	B
M11402	MSP11402	14	20.7	20.7	9.0	50.0	B
M11502	MSP11502	15	21.6	21.6	9.0	50.0	B

6 PT SHEET METAL
Standard Length

PART NUMBER 6pt	PART NUMBER Magnetic	SIZE (mm)	D1 (mm)	D2 (mm)	T (mm)	L (mm)	STYLE
S10501	MS10501	5	9.1	13.0	2.1	25.0	A
S10551	MS10551	5.5	9.7	13.0	2.1	25.0	A
S10601	MS10601	6	10.3	13.0	2.1	25.0	A
S10701	MS10701	7	11.6	13.0	2.5	25.0	A
S10801	MS10801	8	12.8	13.0	2.9	25.0	A
S10901	MS10901	9	14.1	14.1	3.7	25.0	B
S11001	MS11001	10	15.6	15.6	3.7	25.0	B
S11101	MS11101	11	16.6	16.6	4.3	25.0	B
S11201	MS11201	12	17.8	17.8	4.4	25.0	B
S11301	MS11301	13	19.1	19.1	4.4	25.0	B



Sheet metal sockets do not have a lead in chamfer for better engagement with sheet metal screws

BOLD part numbers are available for fast delivery.

1/4" IMPACT SOCKETS MM



3/8"



1/4"

EXTERNAL TORX®

Standard Length

PART NUMBER	SIZE (Torx)	D1 (Inch)	D2 (Inch)	T (Inch)	L (Inch)	STYLE
1TE41	E-4	0.30	0.51	0.14	1.0	C
1TE51	E-5	0.32	0.51	0.17	1.0	C
1TE61	E-6	0.35	0.51	0.17	1.0	C
1TE71	E-7	0.37	0.51	0.22	1.0	C
1TE81	E-8	0.43	0.51	0.24	1.0	C
1TE101	E-10	0.51	0.51	0.28	1.0	B
1TE121	E-12	0.63	0.63	0.33	1.0	B

1/4" SQUARE DRIVE ADAPTERS

PART NUMBER	MALE SQUARE	SQUARE DRIVE	LENGTH	LOCK TYPE
12EB1	3/8"	1/4"	1"	Ball
12EP1	3/8"	1/4"	1"	Pin

1/4"

IMPACT SOCKETS TORX | EXTENSIONS | ADAPTERS

1/4"



1/4"

1/4" SQUARE DRIVE EXTENSIONS

PART NUMBER	MALE SQUARE	SQUARE DRIVE	LENGTH	LOCK TYPE
11EP1	1/4"	1/4"	1"	Ball
11EB1	1/4"	1/4"	1"	Pin
11EB2	1/4"	1/4"	2"	Ball
11EP2	1/4"	1/4"	2"	Pin
11EP3	1/4"	1/4"	3"	Pin
11EB4	1/4"	1/4"	4"	Ball
11EP4	1/4"	1/4"	4"	Pin
11EB6	1/4"	1/4"	6"	Ball
11EP6	1/4"	1/4"	6"	Pin
11EP8	1/4"	1/4"	8"	Pin
11EP10	1/4"	1/4"	10"	Pin
11EP12	1/4"	1/4"	12"	Pin



Ball lock provides quick change outs



Pin lock provides extra security and safety

Extended Reach Options Available up to 12"



BOLD part numbers are available for fast delivery.

TORX® is a registered trademark of Acument Global Technologies, LLC.

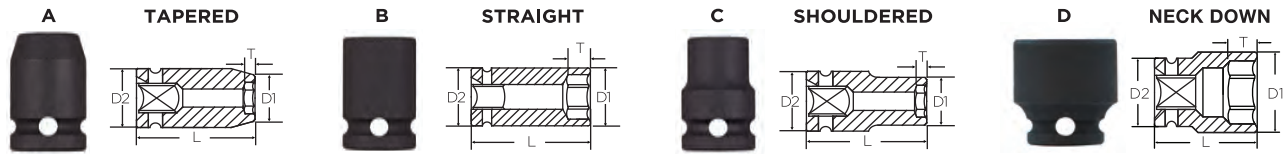

6 PT & 12 PT							
Standard Length							
PART NUMBER 6pt	PART NUMBER 12pt	SIZE (Inch)	D1 (Inch)	D2 (Inch)	T (Inch)	L (Inch)	STYLE
20141	20141-D	1/4	0.42	0.75	0.19	1.2	A
29321	29321-D	9/32	0.48	0.75	0.19	1.2	A
25161	25161-D	5/16	0.51	0.75	0.23	1.2	A
211321	211321-D	11/32	0.55	0.75	0.25	1.2	A
20381	20381-D	3/8	0.60	0.75	0.28	1.2	A
27161	27161-D	7/16	0.70	0.75	0.32	1.2	A
20121	20121-D	1/2	0.75	0.75	0.34	1.2	B
29161	29161-D	9/16	0.87	0.87	0.34	1.2	B
20581	20581-D	5/8	0.93	0.87	0.43	1.2	D
211161	211161-D	11/16	0.98	0.87	0.47	1.2	D
20341	20341-D	3/4	1.06	0.87	0.52	1.2	D
213161	213161-D	13/16	1.18	0.87	0.52	1.2	D
20781	20781-D	7/8	1.26	0.87	0.56	1.2	D

6 PT & 12 PT THIN WALL							
Standard Length							
PART NUMBER 6pt	PART NUMBER 12pt	SIZE (Inch)	D1 (Inch)	D2 (Inch)	T (Inch)	L (Inch)	STYLE
20141-T	20141-DT	1/4	0.42	0.75	0.19	1.2	C
29321-T	29321-DT	9/32	0.48	0.75	0.19	1.2	C
25161-T	25161-DT	5/16	0.51	0.75	0.23	1.2	C
211321-T	211321-DT	11/32	0.55	0.75	0.25	1.2	C
20381-T	20381-DT	3/8	0.60	0.75	0.28	1.2	C
27161-T	27161-DT	7/16	0.66	0.75	0.32	1.2	C
20121-T	20121-DT	1/2	0.72	0.75	0.34	1.2	C
29161-T	29161-DT	9/16	0.83	0.87	0.34	1.2	C
20581-T	20581-DT	5/8	0.87	0.87	0.43	1.2	B
211161-T	211161-DT	11/16	0.94	0.87	0.47	1.2	D
20341-T	20341-DT	3/4	1.02	0.87	0.52	1.2	D
213161-T	213161-DT	13/16	1.14	0.87	0.52	1.2	D
20781-T	20781-DT	7/8	1.22	0.87	0.56	1.2	D

6 PT & 12 PT							
Long Length							
PART NUMBER 6pt	PART NUMBER 12pt	SIZE (Inch)	D1 (Inch)	D2 (Inch)	T (Inch)	L (Inch)	STYLE
20142	20142-D	1/4	0.42	0.75	0.19	2.0	A
29322	29322-D	9/32	0.48	0.75	0.19	2.0	A
25162	25162-D	5/16	0.51	0.75	0.23	2.0	A
211322	211322-D	11/32	0.55	0.75	0.25	2.0	A
20382	20382-D	3/8	0.60	0.75	0.28	2.0	A
27162	27162-D	7/16	0.71	0.75	0.32	2.0	A
20122	20122-D	1/2	0.75	0.75	0.34	2.0	B
29162	29162-D	9/16	0.87	0.87	0.55	2.0	B
20582	20582-D	5/8	0.93	0.87	1.00	2.5	D
211162	211162-D	11/16	0.98	0.87	1.00	2.5	D
20342	20342-D	3/4	1.06	0.87	1.00	2.5	D
213162	213162-D	13/16	1.22	0.87	1.00	2.5	D
20782	20782-D	7/8	1.26	0.87	1.00	2.5	D

6 PT & 12 PT THIN WALL							
Long Length							
PART NUMBER 6pt	PART NUMBER 12pt	SIZE (Inch)	D1 (Inch)	D2 (Inch)	T (Inch)	L (Inch)	STYLE
25162-T	25162-DT	5/16	0.51	0.75	0.23	2.0	C
211322-T	211322-DT	11/32	0.55	0.75	0.25	2.0	C
20382-T	20382-DT	3/8	0.60	0.75	0.28	2.0	C
27162-T	27162-DT	7/16	0.66	0.75	0.32	2.0	C
20122-T	20122-DT	1/2	0.71	0.75	0.34	2.0	C
29162-T	29162-DT	9/16	0.83	0.87	0.55	2.5	C
20342-T	20342-DT	3/4	1.02	0.87	0.59	2.5	D



Comprehensive offering of 3/8" square drive impact socket sets available on page 70.

BOLD part numbers are available for fast delivery.

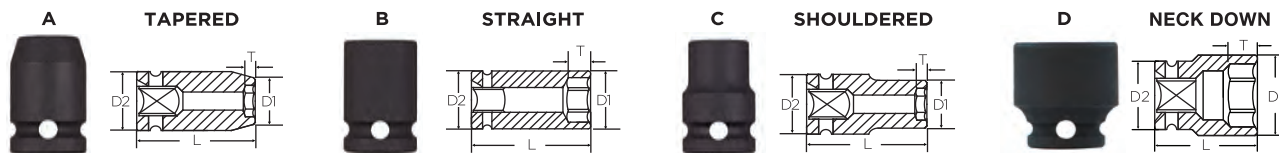

6 PT MAGNETIC

Standard Length

PART NUMBER 6pt	SIZE (Inch)	D1 (Inch)	D2 (Inch)	T (Inch)	L (Inch)	STYLE
M20141	1/4	0.42	0.75	0.19	1.2	A
M29321	9/32	0.48	0.75	0.21	1.2	A
M25161	5/16	0.51	0.75	0.23	1.2	A
M211321	11/32	0.55	0.75	0.25	1.2	A
M20381	3/8	0.60	0.75	0.28	1.2	A
M27161	7/16	0.70	0.75	0.32	1.2	A
M20121	1/2	0.75	0.75	0.34	1.2	B
M29161	9/16	0.87	0.87	0.34	1.2	B
M20581	5/8	0.93	0.87	0.28	1.2	D

6 PT MAGNETIC THIN WALL

Standard Length

PART NUMBER 6pt	SIZE (Inch)	D1 (Inch)	D2 (Inch)	T (Inch)	L (Inch)	STYLE
M20141-T	1/4	0.42	0.75	0.19	1.2	C
M25161-T	5/16	0.51	0.75	0.23	1.2	C
M20381-T	3/8	0.60	0.75	0.28	1.2	C
M27161-T	7/16	0.66	0.75	0.32	1.2	C
M20121-T	1/2	0.72	0.75	0.34	1.2	C
M29161-T	9/16	0.83	0.87	0.34	1.2	C

6 PT FIXED & SPRING LOADED MAGNETIC

Long Length

PART NUMBER Fixed	PART NUMBER Spring Loaded	SIZE (Inch)	D1 (Inch)	D2 (Inch)	T (Inch)	L (Inch)	STYLE
M20142	MSP20142	1/4	0.42	0.75	0.19	2.0	A
M25162	MSP25162	5/16	0.51	0.75	0.23	2.0	A
M20382	MSP20382	3/8	0.60	0.75	0.28	2.0	A
M27162	MSP27162	7/16	0.70	0.75	0.32	2.0	A
M20122	MSP20122	1/2	0.75	0.75	0.34	2.0	B
M29162	MSP29162	9/16	0.87	0.87	0.55	2.0	B
M20582	MSP20582	5/8	0.94	0.87	0.24	2.5	D

6 PT FIXED & SPRING LOADED MAGNETIC THIN WALL

Long Length

PART NUMBER Fixed	PART NUMBER Spring Loaded	SIZE (Inch)	D1 (Inch)	D2 (Inch)	T (Inch)	L (Inch)	STYLE
M20142-T	MSP20142-T	1/4	0.42	0.75	0.19	2.0	C
M25162-T	MSP25162-T	5/16	0.51	0.75	0.23	2.0	C
M20382-T	MSP20382-T	3/8	0.60	0.75	0.28	2.0	C
M27162-T	MSP27162-T	7/16	0.66	0.75	0.32	2.0	C
M20122-T	MSP20122-T	1/2	0.72	0.75	0.34	2.0	C

6 PT MAGNETIC SHEET METAL

Standard Length

PART NUMBER 6pt	SIZE (Inch)	D1 (Inch)	D2 (Inch)	T (Inch)	L (Inch)	STYLE
MS20141	1/4	0.42	0.75	0.08	1.2	A
MS25161	5/16	0.51	0.75	0.11	1.2	A
MS20381	3/8	0.60	0.75	0.14	1.2	A
MS27161	7/16	0.71	0.75	0.16	1.2	A
MS20121	1/2	0.75	0.75	0.17	1.2	B
MS29161	9/16	0.87	0.87	0.26	1.2	B

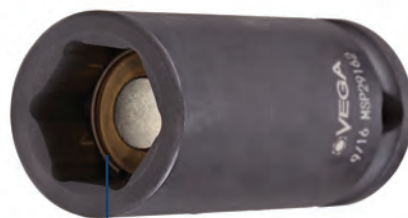

Spring loaded magnets adjust for variable depth applications

BOLD part numbers are available for fast delivery.

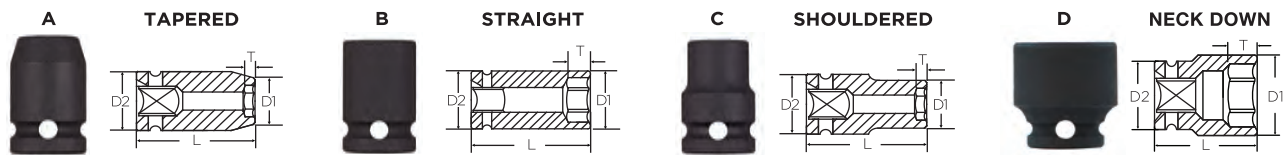

6 PT & 12 PT

Standard Length

PART NUMBER 6pt	PART NUMBER 12pt	SIZE (mm)	D1 (mm)	D2 (mm)	T (mm)	L (mm)	STYLE
20601	20601-D	6	11.6	19.0	5.2	30.0	A
20701	20701-D	7	12.8	19.0	6.0	30.0	A
20801	20801-D	8	14.1	19.0	7.1	30.0	A
20901	20901-D	9	15.3	19.0	7.1	30.0	A
21001	21001-D	10	16.6	19.0	7.1	30.0	A
21101	21101-D	11	17.8	19.0	8.0	30.0	A
21201	21201-D	12	19.0	19.0	8.6	30.0	B
21301	21301-D	13	20.0	20.0	9.2	30.0	B
21401	21401-D	14	21.0	21.0	9.2	30.0	B
21501	21501-D	15	22.0	22.0	10.9	30.0	B
21601	21601-D	16	23.5	22.0	11.0	30.0	D
21701	21701-D	17	24.9	22.0	11.0	30.0	D
21801	21801-D	18	25.9	22.0	12.2	30.0	D
21901	21901-D	19	26.9	22.0	13.0	30.0	D
22101	22101-D	21	29.9	22.0	13.7	30.0	D
22201	22201-D	22	31.9	22.0	14.5	30.0	D

6 PT & 12 PT THIN WALL

Standard Length

PART NUMBER 6pt	PART NUMBER 12pt	SIZE (mm)	D1 (mm)	D2 (mm)	T (mm)	L (mm)	STYLE
20601-T	20601-DT	6	11.6	19.0	4.7	30.0	C
20701-T	20701-DT	7	12.8	19.0	6.0	30.0	C
20801-T	20801-DT	8	14.1	19.0	7.1	30.0	C
20901-T	20901-DT	9	15.3	19.0	7.1	30.0	C
21001-T	21001-DT	10	16.6	19.0	7.1	30.0	C
21101-T	21101-DT	11	17.8	19.0	8.0	30.0	C
21201-T	21201-DT	12	18.0	19.0	8.6	30.0	C
21301-T	21301-DT	13	19.0	19.0	9.2	30.0	B
21401-T	21401-DT	14	20.0	20.0	9.2	30.0	B
21501-T	21501-DT	15	21.0	21.0	10.9	30.0	B
21601-T	21601-DT	16	22.0	22.0	11.0	30.0	B
21701-T	21701-DT	17	23.0	22.0	11.0	30.0	D
21801-T	21801-DT	18	24.0	22.0	12.2	30.0	D
21901-T	21901-DT	19	26.0	22.0	13.0	30.0	D
22101-T	22101-DT	21	29.0	22.0	13.7	30.0	D

6 PT & 12 PT

Long Length

PART NUMBER 6pt	PART NUMBER 12pt	SIZE (mm)	D1 (mm)	D2 (mm)	T (mm)	L (mm)	STYLE
20602	20602-D	6	11.6	19.0	4.7	50.0	A
20702	20702-D	7	12.8	19.0	5.8	50.0	A
20802	20802-D	8	14.1	19.0	6.3	50.0	A
20902	20902-D	9	15.3	19.0	6.9	50.0	A
21002	21002-D	10	16.6	19.0	7.1	50.0	A
21102	21102-D	11	17.8	19.0	8.0	50.0	A
21202	21202-D	12	19.0	19.0	8.6	50.0	B
21302	21302-D	13	20.0	20.0	14.4	50.0	B
21402	21402-D	14	21.0	21.0	14.4	50.0	B
21502	21502-D	15	22.0	22.0	14.4	50.0	B
21602	21602-D	16	23.5	22.0	26.0	63.0	D
21702	21702-D	17	24.9	22.0	26.0	63.0	D
21802	21802-D	18	25.5	22.0	26.0	63.0	D
21902	21902-D	19	26.5	22.0	26.0	63.0	D
22102	22102-D	21	29.9	22.0	26.0	63.0	D
22202	22202-D	22	31.3	22.0	26.0	63.0	D



The corners of our hex and square openings have a radius for stress relief providing more torque while reducing fastener rounding

BOLD part numbers are available for fast delivery.

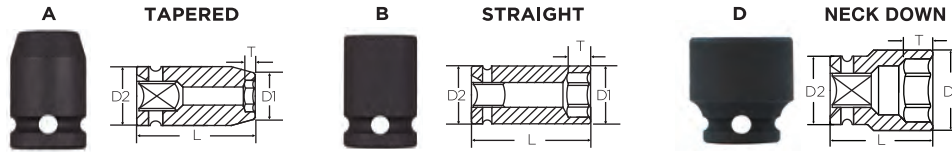

6 PT MAGNETIC

Standard Length

PART NUMBER 6pt	SIZE (mm)	D1 (mm)	D2 (mm)	T (mm)	L (mm)	STYLE
M20601	6	11.6	19.0	4.7	30.0	A
M20701	7	12.8	19.0	4.7	30.0	A
M20801	8	14.1	19.0	4.7	30.0	A
M20901	9	15.3	19.0	4.7	30.0	A
M21001	10	16.6	19.0	4.7	30.0	A
M21101	11	17.8	19.0	4.7	30.0	A
M21201	12	19.0	19.0	6.0	30.0	B
M21301	13	20.0	20.0	6.0	30.0	B
M21401	14	21.0	21.0	7.2	30.0	B
M21501	15	22.0	22.0	7.2	30.0	B
M21601	16	23.5	22.0	9.6	30.0	D
M21701	17	24.0	22.0	9.6	30.0	D
M21801	18	25.0	22.0	10.2	30.0	D

6 PT MAGNETIC THIN WALL

Standard Length

PART NUMBER 6pt	SIZE (mm)	D1 (mm)	D2 (mm)	T (mm)	L (mm)	STYLE
M20801-T	8	14.1	19.0	4.7	30.0	A
M20901-T	9	15.3	19.0	4.7	30.0	A
M21001-T	10	16.6	19.0	4.7	30.0	A
M21101-T	11	17.8	19.0	4.7	30.0	A
M21201-T	12	19.0	19.0	6.0	30.0	B
M21301-T	13	20.0	20.0	6.0	30.0	B
M21401-T	14	21.0	21.0	7.2	30.0	B
M21501-T	15	22.0	22.0	7.2	30.0	B

6 PT FIXED & SPRING LOADED MAGNETIC

Long Length

PART NUMBER Fixed	PART NUMBER Spring Loaded	SIZE (mm)	D1 (mm)	D2 (mm)	T (mm)	L (mm)	STYLE
M20602	MSP20602	6	11.6	19.0	4.7	50.0	A
M20702	MSP20702	7	12.8	19.0	4.7	50.0	A
M20802	MSP20802	8	14.1	19.0	4.7	50.0	A
M20902	MSP20902	9	15.3	19.0	4.7	50.0	A
M21002	MSP21002	10	16.6	19.0	4.7	50.0	A
M21102	MSP21102	11	17.8	19.0	4.7	50.0	A
M21202	MSP21202	12	19.0	19.0	6.0	50.0	B
M21302	MSP21302	13	20.0	20.0	6.0	50.0	B
M21402	MSP21402	14	21.0	21.0	7.2	50.0	B
M21502	MSP21502	15	22.0	22.0	7.2	50.0	B
M21602	MSP21602	16	23.5	22.0	9.6	63.0	D
M21702	MSP21702	17	24.0	22.0	9.6	63.0	D
M21802	MSP21802	18	25.0	22.0	10.2	63.0	D

6 PT MAGNETIC SHEET METAL

Standard Length

PART NUMBER 6pt	SIZE (mm)	D1 (mm)	D2 (mm)	T (mm)	L (mm)	STYLE
MS20701	7	12.8	19.0	2.1	30.0	A
MS20801	8	14.1	19.0	2.9	30.0	A
MS20901	9	15.3	19.0	3.7	30.0	A
MS21001	10	16.6	19.0	3.7	30.0	A
MS21101	11	17.8	19.0	4.3	30.0	A
MS21301	13	20.0	20.0	4.4	30.0	B



Thin wall sockets for countersunk or limited clearance applications

BOLD part numbers are available for fast delivery.

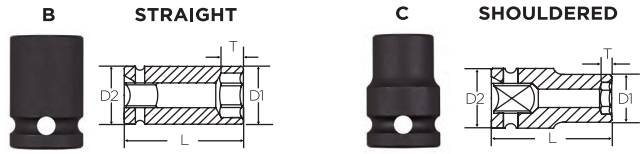

EXTERNAL TORX®

Standard Length

PART NUMBER	SIZE (Torx)	D1 (Inch)	D2 (Inch)	T (Inch)	L (Inch)	STYLE
2TE61	E-6	0.35	0.75	0.17	1.3	C
2TE71	E-7	0.39	0.75	0.22	1.3	C
2TE81	E-8	0.43	0.75	0.24	1.3	C
2TE101	E-10	0.51	0.75	0.28	1.3	C
2TE121	E-12	0.63	0.75	0.33	1.3	C
2TE141	E-14	0.71	0.75	0.38	1.3	C
2TE161	E-16	0.75	0.75	0.43	1.3	B



3/8" SQUARE DRIVE ADAPTERS

PART NUMBER	MALE SQUARE	SQUARE DRIVE	LENGTH	LOCK TYPE
21EB1	1/4"	3/8"	1-1/4"	Ball
21EP1	1/4"	3/8"	1-1/4"	Pin
21EB2	1/4"	3/8"	2"	Ball
21EP2	1/4"	3/8"	2"	Pin
21EB3	1/4"	3/8"	3"	Ball
21EP3	1/4"	3/8"	3"	Pin
21EB4	1/4"	3/8"	4"	Ball
21EP4	1/4"	3/8"	4"	Pin
21EB5	1/4"	3/8"	5"	Ball
21EP5	1/4"	3/8"	5"	Pin
21EB6	1/4"	3/8"	6"	Ball
21EP6	1/4"	3/8"	6"	Pin
23EB1	1/2"	3/8"	1-1/2"	Ball
23EP1	1/2"	3/8"	1-1/2"	Pin
23EB2	1/2"	3/8"	2"	Ball
23EP2	1/2"	3/8"	2"	Pin
23EB3	1/2"	3/8"	3"	Ball
23EP3	1/2"	3/8"	3"	Pin
23EB4	1/2"	3/8"	4"	Ball
23EP4	1/2"	3/8"	4"	Pin
23EB5	1/2"	3/8"	5"	Ball
23EP5	1/2"	3/8"	5"	Pin
23EB6	1/2"	3/8"	6"	Ball
23EP6	1/2"	3/8"	6"	Pin



3/8" SQUARE DRIVE EXTENSIONS

PART NUMBER	MALE SQUARE	SQUARE DRIVE	LENGTH	LOCK TYPE
22EB1	3/8"	3/8"	1-3/8"	Ball
22EP1	3/8"	3/8"	1-3/8"	Pin
22EB2	3/8"	3/8"	2"	Ball
22EP2	3/8"	3/8"	2"	Pin
22EB3	3/8"	3/8"	3"	Ball
22EP3	3/8"	3/8"	3"	Pin
22EB4	3/8"	3/8"	4"	Ball
22EP4	3/8"	3/8"	4"	Pin
22EB5	3/8"	3/8"	5"	Ball
22EP5	3/8"	3/8"	5"	Pin
22EB6	3/8"	3/8"	6"	Ball
22EP6	3/8"	3/8"	6"	Pin
22EB8	3/8"	3/8"	8"	Ball
22EP8	3/8"	3/8"	8"	Pin
22EB10	3/8"	3/8"	10"	Ball
22EP10	3/8"	3/8"	10"	Pin
22EB12	3/8"	3/8"	12"	Ball
22EP12	3/8"	3/8"	12"	Pin



Ball lock provides quick change outs



Pin lock provides extra security and safety

Extended Reach Options Available up to 12"

12"



BOLD part numbers are available for fast delivery.

TORX® is a registered trademark of Acument Global Technologies, LLC.

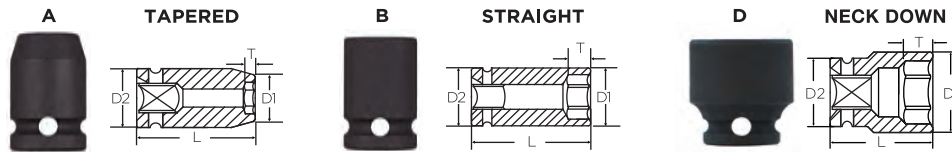

6 PT & 12 PT

Standard Length

PART NUMBER 6pt	PART NUMBER 12pt	SIZE (Inch)	D1 (Inch)	D2 (Inch)	T (Inch)	L (Inch)	STYLE
35161	35161-D	5/16	0.55	0.98	0.47	1.5	A
30381	30381-D	3/8	0.63	0.98	0.47	1.5	A
37161	37161-D	7/16	0.72	0.98	0.47	1.5	A
30121	30121-D	1/2	0.81	0.98	0.47	1.5	A
39161	39161-D	9/16	0.90	0.98	0.47	1.5	A
30581	30581-D	5/8	0.98	0.98	0.51	1.5	B
311161	311161-D	11/16	1.02	1.02	0.59	1.5	B
30341	30341-D	3/4	1.10	1.10	0.63	1.5	B
313161	313161-D	13/16	1.18	1.18	0.63	1.5	B
30781	30781-D	7/8	1.26	1.26	0.63	1.5	B
315161	315161-D	15/16	1.34	1.34	0.91	1.8	B
316161	316161-D	1	1.42	1.42	0.94	1.8	B
317161	317161-D	1-1/16	1.50	1.50	0.94	1.8	B
318161	318161-D	1-1/8	1.57	1.50	0.98	1.8	D
319161	319161-D	1-3/16	1.57	1.50	0.98	1.8	D
320161	320161-D	1-1/4	1.69	1.50	0.98	1.8	D
321161	321161-D	1-5/16	1.81	1.50	0.98	1.8	D
322161	322161-D	1-3/8	2.01	1.50	1.06	2.0	D
323161	323161-D	1-7/16	2.13	1.50	1.06	2.0	D
324161	324161-D	1-1/2	2.13	1.50	1.06	2.0	D
326161	326161-D	1-5/8	2.28	1.50	1.06	2.0	D

6 PT & 12 PT

Long Length

PART NUMBER 6pt	PART NUMBER 12pt	SIZE (Inch)	D1 (Inch)	D2 (Inch)	T (Inch)	L (Inch)	STYLE
35163	35163-D	5/16	0.55	0.98	0.59	3.2	A
30383	30383-D	3/8	0.63	0.98	0.59	3.2	A
37163	37163-D	7/16	0.72	0.98	0.59	3.2	A
30123	30123-D	1/2	0.81	0.98	0.59	3.2	A
39163	39163-D	9/16	0.90	0.98	1.18	3.2	A
30583	30583-D	5/8	0.98	0.98	1.18	3.2	B
311163	311163-D	11/16	1.02	1.02	1.18	3.2	B
30343	30343-D	3/4	1.10	1.10	1.26	3.2	B
313163	313163-D	13/16	1.18	1.18	1.26	3.2	B
30783	30783-D	7/8	1.26	1.26	1.26	3.2	B
315163	315163-D	15/16	1.34	1.34	1.26	3.2	B
316163	316163-D	1	1.42	1.42	1.26	3.2	B
317163	317163-D	1-1/16	1.50	1.50	1.42	3.2	B
318163	318163-D	1-1/8	1.57	1.50	1.26	3.2	D
319163	319163-D	1-3/16	1.57	1.50	1.26	3.2	D
320163	320163-D	1-1/4	1.69	1.50	1.26	3.2	D
321163	321163-D	1-5/16	1.81	1.50	1.42	3.2	D
322163	322163-D	1-3/8	2.01	1.50	1.42	3.2	D
323163	323163-D	1-7/16	2.13	1.50	1.42	3.2	D
324163	324163-D	1-1/2	2.13	1.50	1.42	3.2	D
326163	326163-D	1-5/8	2.28	1.50	1.42	3.2	D



Comprehensive offering of 1/2" square drive impact socket sets available on page 71.

BOLD part numbers are available for fast delivery.

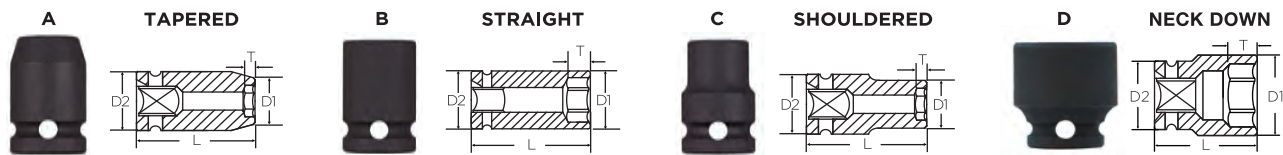

6 PT & 12 PT THIN WALL

Standard Length

PART NUMBER 6pt	PART NUMBER 12pt	SIZE (Inch)	D1 (Inch)	D2 (Inch)	T (Inch)	L (Inch)	STYLE
35161-T	35161-DT	5/16	0.55	0.98	0.47	1.5	C
30381-T	30381-DT	3/8	0.63	0.98	0.47	1.5	C
37161-T	37161-DT	7/16	0.72	0.98	0.47	1.5	C
30121-T	30121-DT	1/2	0.81	0.98	0.47	1.5	C
39161-T	39161-DT	9/16	0.90	0.98	0.47	1.5	C
30581-T	30581-DT	5/8	0.94	0.98	0.47	1.5	C
311161-T	311161-DT	11/16	0.98	0.98	0.59	1.5	B
30341-T	30341-DT	3/4	1.06	1.06	0.63	1.5	B
313161-T	313161-DT	13/16	1.14	1.14	0.63	1.5	B
30781-T	30781-DT	7/8	1.22	1.22	0.63	1.5	B
315161-T	315161-DT	15/16	1.30	1.30	0.91	1.8	B
316161-T	316161-DT	1	1.37	1.37	0.94	1.8	B
317161-T	317161-DT	1-1/16	1.45	1.45	0.94	1.8	B
318161-T	318161-DT	1-1/8	1.54	1.50	0.98	1.8	D
319161-T	319161-DT	1-3/16	1.54	1.50	0.98	1.8	D
320161-T	320161-DT	1-1/4	1.65	1.50	0.98	1.8	D

6 PT MAGNETIC

Standard Length

PART NUMBER 6pt	SIZE (Inch)	D1 (Inch)	D2 (Inch)	T (Inch)	L (Inch)	STYLE
M35161	5/16	0.57	0.98	0.16	1.5	A
M30381	3/8	0.63	0.98	0.18	1.5	A
M37161	7/16	0.71	0.98	0.20	1.5	A
M30121	1/2	0.79	0.98	0.24	1.5	A
M39161	9/16	0.87	0.98	0.24	1.5	A
M30581	5/8	0.98	0.98	0.28	1.5	B



All magnetic sockets feature industrial strength rare earth magnets

6 PT & 12 PT THIN WALL

Long Length

PART NUMBER 6pt	PART NUMBER 12pt	SIZE (Inch)	D1 (Inch)	D2 (Inch)	T (Inch)	L (Inch)	STYLE
35163-T	35163-DT	5/16	0.55	0.98	0.59	3.2	C
30383-T	30383-DT	3/8	0.63	0.98	0.59	3.2	C
37163-T	37163-DT	7/16	0.72	0.98	0.59	3.2	C
30123-T	30123-DT	1/2	0.81	0.98	0.59	3.2	C
39163-T	39163-DT	9/16	0.90	0.98	1.18	3.2	C
30583-T	30583-DT	5/8	0.94	0.98	1.18	3.2	C
311163-T	311163-DT	11/16	0.98	0.98	1.18	3.2	B
30343-T	30343-DT	3/4	1.06	1.06	1.26	3.2	B
313163-T	313163-DT	13/16	1.14	1.14	1.26	3.2	B
30783-T	30783-DT	7/8	1.22	1.22	1.26	3.2	B
315163-T	315163-DT	15/16	1.30	1.30	1.26	3.2	B
316163-T	316163-DT	1	1.37	1.37	1.26	3.2	B
317163-T	317163-DT	1-1/16	1.45	1.45	1.26	3.2	B

6 PT MAGNETIC SHEET METAL

Standard Length

PART NUMBER 6pt	SIZE (Inch)	D1 (Inch)	D2 (Inch)	T (Inch)	L (Inch)	STYLE
MS35161	5/16	0.57	0.98	0.12	1.4	A
MS30381	3/8	0.63	0.98	0.12	1.4	A
MS37161	7/16	0.71	0.98	0.16	1.4	A
MS30121	1/2	0.79	0.98	0.21	1.4	A
MS39161	9/16	0.87	0.98	0.21	1.4	A



Sheet metal sockets do not have a lead in chamfer for better engagement with sheet metal screws

BOLD part numbers are available for fast delivery.

1/2" IMPACT SOCKETS SAE

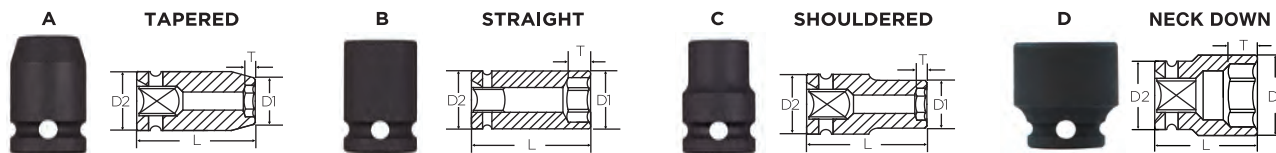

6 PT & 12 PT

Standard Length

PART NUMBER 6pt	PART NUMBER 12pt	SIZE (mm)	D1 (mm)	D2 (mm)	T (mm)	L (mm)	STYLE
31001	31001-D	10	17.8	25.0	12.0	38.0	A
31101	31101-D	11	19.0	25.0	12.0	38.0	A
31201	31201-D	12	20.3	25.0	12.0	38.0	A
31301	31301-D	13	21.5	25.0	12.0	38.0	A
31401	31401-D	14	22.8	25.0	13.0	38.0	A
31501	31501-D	15	25.0	25.0	13.0	38.0	B
31601	31601-D	16	25.0	25.0	13.0	38.0	B
31701	31701-D	17	27.0	27.0	15.0	38.0	B
31801	31801-D	18	27.0	27.0	15.0	38.0	B
31901	31901-D	19	28.0	28.0	16.0	38.0	B
32101	32101-D	21	30.0	30.0	16.0	38.0	B
32201	32201-D	22	32.6	32.6	16.0	38.0	B
32401	32401-D	24	34.0	34.0	23.0	45.0	B
32701	32701-D	27	38.0	38.0	23.0	45.0	B
33001	33001-D	30	40.5	38.0	23.0	45.0	D
33201	33201-D	32	42.8	38.0	23.0	45.0	D
33601	33601-D	36	49.7	38.0	25.0	50.0	D

6 PT & 12 PT

Long Length

PART NUMBER 6pt	PART NUMBER 12pt	SIZE (mm)	D1 (mm)	D2 (mm)	T (mm)	L (mm)	STYLE
31003	31003-D	10	17.8	25.0	15.0	80.0	A
31103	31103-D	11	19.0	25.0	15.0	80.0	A
31203	31203-D	12	20.3	25.0	15.0	80.0	A
31303	31303-D	13	21.5	25.0	15.0	80.0	A
31403	31403-D	14	22.8	25.0	30.0	80.0	A
31503	31503-D	15	25.0	25.0	30.0	80.0	B
31603	31603-D	16	25.0	25.0	30.0	80.0	B
31703	31703-D	17	27.0	27.0	30.0	80.0	B
31803	31803-D	18	27.0	27.0	32.0	80.0	B
31903	31903-D	19	28.0	28.0	32.0	80.0	B
32103	32103-D	21	30.0	30.0	32.0	80.0	B
32203	32203-D	22	32.6	32.6	32.0	80.0	B
32403	32403-D	24	34.0	34.0	32.0	80.0	B
32703	32703-D	27	38.0	38.0	36.0	80.0	B
33003	33003-D	30	40.5	38.0	36.0	80.0	D
33203	33203-D	32	42.8	38.0	36.0	80.0	D
33603	33603-D	36	49.7	38.0	36.0	80.0	D



Comprehensive offering of 1/2" square drive impact socket sets available on page 71.

BOLD part numbers are available for fast delivery.

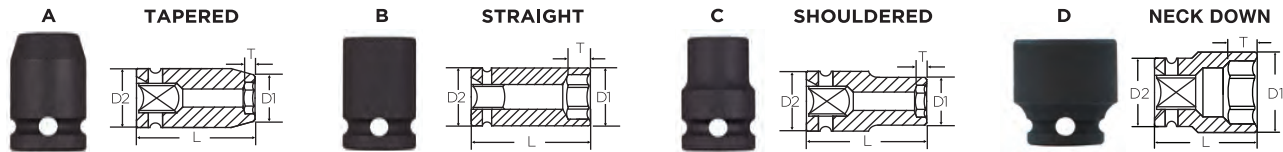

6 PT & 12 PT THIN WALL

Standard Length

PART NUMBER 6pt	PART NUMBER 12pt	SIZE (mm)	D1 (mm)	D2 (mm)	T (mm)	L (mm)	STYLE
31001-T	31001-DT	10	17.8	25.0	12.0	38.0	C
31101-T	31101-DT	11	19.0	25.0	12.0	38.0	C
31201-T	31201-DT	12	20.3	25.0	12.0	38.0	C
31301-T	31301-DT	13	21.5	25.0	12.0	38.0	C
31401-T	31401-DT	14	22.8	25.0	13.0	38.0	C
31501-T	31501-DT	15	24.0	25.0	13.0	38.0	C
31601-T	31601-DT	16	24.0	25.0	13.0	38.0	C
31701-T	31701-DT	17	26.0	26.0	15.0	38.0	B
31801-T	31801-DT	18	26.0	26.0	15.0	38.0	B
31901-T	31901-DT	19	27.0	27.0	16.0	38.0	B
32101-T	32101-DT	21	28.9	28.9	16.0	38.0	B
32201-T	32201-DT	22	29.6	29.6	16.0	38.0	B

6 PT & 12 PT MAGNETIC

Standard Length

PART NUMBER 6pt	PART NUMBER 12pt	SIZE (mm)	D1 (mm)	D2 (mm)	T (mm)	L (mm)	STYLE
M31001	M31001-D	10	16.7	25.0	4.7	38.0	A
M31101	M31101-D	11	18.0	25.0	4.7	38.0	A
M31201	M31201-D	12	19.0	25.0	6.0	38.0	A
M31301	M31301-D	13	20.2	25.0	6.0	38.0	A
M31401	M31401-D	14	21.5	25.0	7.2	38.0	A
M31501	M31501-D	15	25.0	25.0	7.2	38.0	B
M31601	M31601-D	16	25.0	25.0	9.6	38.0	B
M31701	M31701-D	17	27.0	27.0	9.6	38.0	B
M31801	M31801-D	18	27.0	27.0	10.2	38.0	B
M31901	M31901-D	19	28.0	28.0	10.2	38.0	B
M32101	M32101-D	21	29.9	29.9	10.2	38.0	B

6 PT & 12 PT THIN WALL

Long Length

PART NUMBER 6pt	PART NUMBER 12pt	SIZE (mm)	D1 (mm)	D2 (mm)	T (mm)	L (mm)	STYLE
31003-T	31003-DT	10	17.8	25.0	15.0	80.0	C
31103-T	31103-DT	11	19.0	25.0	15.0	80.0	C
31203-T	31203-DT	12	20.3	25.0	15.0	80.0	C
31303-T	31303-DT	13	21.5	25.0	15.0	80.0	C
31403-T	31403-DT	14	22.8	25.0	30.0	80.0	C
31503-T	31503-DT	15	24.0	25.0	30.0	80.0	C
31603-T	31603-DT	16	24.0	25.0	30.0	80.0	C
31703-T	31703-DT	17	26.0	26.0	30.0	80.0	B
31803-T	31803-DT	18	26.0	26.0	32.0	80.0	B
31903-T	31903-DT	19	27.0	27.0	32.0	80.0	B
32103-T	32103-DT	21	28.9	28.9	32.0	80.0	B
32203-T	32203-DT	22	29.6	29.6	32.0	80.0	B
32403-T	32403-DT	24	32.9	32.9	32.0	80.0	B
32703-T	32703-DT	27	36.9	36.9	36.0	80.0	B
33003-T	33003-DT	30	39.5	38.0	36.0	80.0	D
33203-T	33203-DT	32	41.8	38.0	36.0	80.0	D



Thin wall sockets for countersunk or limited clearance applications

BOLD part numbers are available for fast delivery.

1/2"

IMPACT SOCKETS MM



EXTERNAL TORX®

Standard Length

PART NUMBER	SIZE (Torx)	D1 (Inch)	D2 (Inch)	T (Inch)	L (Inch)	STYLE
3TE81	E-8	0.47	0.98	0.24	1.5	C
3TE101	E-10	0.55	0.98	0.28	1.5	C
3TE121	E-12	0.63	0.98	0.33	1.5	C
3TE141	E-14	0.75	0.98	0.38	1.5	C
3TE161	E-16	0.83	0.98	0.43	1.5	C
3TE181	E-18	0.91	0.98	0.47	1.5	C
3TE201	E-20	0.98	0.98	0.53	1.5	B

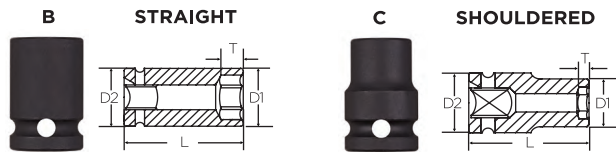

1/2" SQUARE DRIVE ADAPTERS

PART NUMBER	MALE SQUARE	SQUARE DRIVE	LENGTH	LOCK TYPE
31EB2	1/4"	1/2"	1-1/4"	Ball
31EP2	1/4"	1/2"	1-1/4"	Pin
32EB1	3/8"	1/2"	1-1/2"	Ball
32EP1	3/8"	1/2"	1-1/2"	Pin
32EB2	3/8"	1/2"	2"	Ball
32EP2	3/8"	1/2"	2"	Pin
32EB3	3/8"	1/2"	3"	Ball
32EP3	3/8"	1/2"	3"	Pin
32EB4	3/8"	1/2"	4"	Ball
32EP4	3/8"	1/2"	4"	Pin
32EB5	3/8"	1/2"	5"	Ball
32EP5	3/8"	1/2"	5"	Pin
32EB6	3/8"	1/2"	6"	Ball
32EP6	3/8"	1/2"	6"	Pin
32EB8	3/8"	1/2"	8"	Ball
32EP8	3/8"	1/2"	8"	Pin
32EB9	3/8"	1/2"	9"	Ball
32EP9	3/8"	1/2"	9"	Pin
32EB10	3/8"	1/2"	10"	Ball
32EP10	3/8"	1/2"	10"	Pin
32EB12	3/8"	1/2"	12"	Ball



1/2" SQUARE DRIVE EXTENSIONS

PART NUMBER	MALE SQUARE	SQUARE DRIVE	LENGTH	LOCK TYPE
33EB1	1/2"	1/2"	1-3/8"	Ball
33EP1	1/2"	1/2"	1-3/8"	Pin
33EB2	1/2"	1/2"	2"	Ball
33EP2	1/2"	1/2"	2"	Pin
33EB3	1/2"	1/2"	3"	Ball
33EP3	1/2"	1/2"	3"	Pin
33EB4	1/2"	1/2"	4"	Ball
33EP4	1/2"	1/2"	4"	Pin
33EB5	1/2"	1/2"	5"	Ball
33EP5	1/2"	1/2"	5"	Pin
33EB6	1/2"	1/2"	6"	Ball
33EP6	1/2"	1/2"	6"	Pin
33EB8	1/2"	1/2"	8"	Ball
33EP8	1/2"	1/2"	8"	Pin
33EB9	1/2"	1/2"	9"	Ball
33EP9	1/2"	1/2"	9"	Pin
33EB10	1/2"	1/2"	10"	Ball
33EP10	1/2"	1/2"	10"	Pin
33EB12	1/2"	1/2"	12"	Ball
33EP12	1/2"	1/2"	12"	Pin



Ball lock provides quick change outs



Pin lock provides extra security and safety

Extended Reach Options Available up to 12"



BOLD part numbers are available for fast delivery.

TORX® is a registered trademark of Acument Global Technologies, LLC.

1/4" SQUARE DRIVE IMPACT SOCKET SETS

PART NUMBER	PIECE COUNT	SIZES		
116SA7	7	3/16", 1/4", 5/16", 3/8", 7/16", 1/2", 9/16"		
OPENING	LENGTH	MAGNET	WALL THICKNESS	SIZE
6 Point	Standard	None	Standard	SAE

PART NUMBER	PIECE COUNT	SIZES		
126SA7	7	3/16", 1/4", 5/16", 3/8", 7/16", 1/2", 9/16"		
OPENING	LENGTH	MAGNET	WALL THICKNESS	SIZE
6 Point	Long	None	Standard	SAE

PART NUMBER	PIECE COUNT	SIZES		
M116SA7	7	3/16", 1/4", 5/16", 3/8", 7/16", 1/2", 9/16"		
OPENING	LENGTH	MAGNET	WALL THICKNESS	SIZE
6 Point	Standard	Fixed	Standard	SAE

PART NUMBER	PIECE COUNT	SIZES		
MSP126SA7	7	1/4", 5/16", 3/8", 7/16", 1/2", 9/16", 5/8"		
OPENING	LENGTH	MAGNET	WALL THICKNESS	SIZE
6 Point	Long	Spring	Standard	SAE

PART NUMBER	PIECE COUNT	SIZES		
116M7	7	7, 8, 9, 10, 11, 12, 13		
OPENING	LENGTH	MAGNET	WALL THICKNESS	SIZE
6 Point	Standard	None	Standard	Metric

PART NUMBER	PIECE COUNT	SIZES		
116M11	11	5, 6, 7, 8, 9, 10, 11, 12, 13, 14, 15		
OPENING	LENGTH	MAGNET	WALL THICKNESS	SIZE
6 Point	Standard	None	Standard	Metric

PART NUMBER	PIECE COUNT	SIZES		
126M7	7	7, 8, 9, 10, 11, 12, 13		
OPENING	LENGTH	MAGNET	WALL THICKNESS	SIZE
6 Point	Long	None	Standard	Metric

PART NUMBER	PIECE COUNT	SIZES		
126M10	10	5, 6, 7, 8, 9, 10, 11, 12, 13, 14		
OPENING	LENGTH	MAGNET	WALL THICKNESS	SIZE
6 Point	Long	None	Standard	Metric

PART NUMBER	PIECE COUNT	SIZES		
M116M7	7	7, 8, 9, 10, 11, 12, 13		
OPENING	LENGTH	MAGNET	WALL THICKNESS	SIZE
6 Point	Standard	Fixed	Standard	Metric

PART NUMBER	PIECE COUNT	SIZES		
MSP126M7	7	7, 8, 9, 10, 11, 12, 13		
OPENING	LENGTH	MAGNET	WALL THICKNESS	SIZE
6 Point	Long	Spring	Standard	Metric

PART NUMBER	PIECE COUNT	SIZES		
1TE7	7	E-4, E-5, E-6, E-7, E-8, E-10, E-12		
OPENING	LENGTH	MAGNET	WALL THICKNESS	SIZE
TORX®	Standard	None	Standard	TORX®



1/4" IMPACT SOCKET SETS

TORX® is a registered trademark of Acument Global Technologies, LLC.

3/8" SQUARE DRIVE IMPACT SOCKET SETS

PART NUMBER	PIECE COUNT	SIZES		
216SA9	9	1/4", 5/16", 3/8", 7/16", 1/2", 9/16", 5/8", 11/16", 3/4"		
OPENING	LENGTH	MAGNET	WALL THICKNESS	SIZE
6 Point	Standard	None	Standard	SAE



PART NUMBER	PIECE COUNT	SIZES		
226SA9	9	1/4", 5/16", 3/8", 7/16", 1/2", 9/16", 5/8", 11/16", 3/4"		
OPENING	LENGTH	MAGNET	WALL THICKNESS	SIZE
6 Point	Long	None	Standard	SAE



PART NUMBER	PIECE COUNT	SIZES		
216SA9-T	9	1/4", 5/16", 3/8", 7/16", 1/2", 9/16", 5/8", 11/16", 3/4"		
OPENING	LENGTH	MAGNET	WALL THICKNESS	SIZE
6 Point	Standard	None	Thin	SAE



PART NUMBER	PIECE COUNT	SIZES		
M216SA7	7	1/4", 5/16", 3/8", 7/16", 1/2", 9/16", 5/8"		
OPENING	LENGTH	MAGNET	WALL THICKNESS	SIZE
6 Point	Standard	Fixed	Standard	SAE



PART NUMBER	PIECE COUNT	SIZES		
MSP226SA7	7	1/4", 5/16", 3/8", 7/16", 1/2", 9/16", 5/8"		
OPENING	LENGTH	MAGNET	WALL THICKNESS	SIZE
6 Point	Long	Spring	Standard	SAE



PART NUMBER	PIECE COUNT	SIZES		
216M11	11	7, 8, 9, 10, 11, 12, 13, 14, 15, 16, 17		
OPENING	LENGTH	MAGNET	WALL THICKNESS	SIZE
6 Point	Standard	None	Standard	Metric



PART NUMBER	PIECE COUNT	SIZES		
226M11	11	7, 8, 9, 10, 11, 12, 13, 14, 15, 16, 17		
OPENING	LENGTH	MAGNET	WALL THICKNESS	SIZE
6 Point	Long	None	Standard	Metric



PART NUMBER	PIECE COUNT	SIZES		
216M11-T	11	7, 8, 9, 10, 11, 12, 13, 14, 15, 16, 17		
OPENING	LENGTH	MAGNET	WALL THICKNESS	SIZE
6 Point	Standard	None	Thin	Metric



PART NUMBER	PIECE COUNT	SIZES		
M216M11	11	7, 8, 9, 10, 11, 12, 13, 14, 15, 16, 17		
OPENING	LENGTH	MAGNET	WALL THICKNESS	SIZE
6 Point	Standard	Fixed	Standard	Metric



PART NUMBER	PIECE COUNT	SIZES		
MSP226M11	11	7, 8, 9, 10, 11, 12, 13, 14, 15, 16, 17		
OPENING	LENGTH	MAGNET	WALL THICKNESS	SIZE
6 Point	Long	Spring	Standard	Metric



PART NUMBER	PIECE COUNT	SIZES		
2TE7	7	E-6, E-7, E-8, E-10, E-12, E-14, E-16		
OPENING	LENGTH	MAGNET	WALL THICKNESS	SIZE
TORX®	Standard	None	Standard	TORX®



TORX® is a registered trademark of Acument Global Technologies, LLC.

1/2" SQUARE DRIVE IMPACT SOCKET SETS

PART NUMBER	PIECE COUNT	SIZES		
316SA11	11	1/2", 9/16", 5/8", 11/16", 3/4", 13/16", 7/8", 15/16", 1", 1-1/16", 1-1/8"		
OPENING	LENGTH	MAGNET	WALL THICKNESS	SIZE
⊙ 6 Point	Standard	None	Standard	SAE



PART NUMBER	PIECE COUNT	SIZES		
336SA11	11	1/2", 9/16", 5/8", 11/16", 3/4", 13/16", 7/8", 15/16", 1", 1-1/16", 1-1/8"		
OPENING	LENGTH	MAGNET	WALL THICKNESS	SIZE
⊙ 6 Point	Long	None	Standard	SAE



PART NUMBER	PIECE COUNT	SIZES		
316SA14	14	3/8", 7/16", 1/2", 9/16", 5/8", 11/16", 3/4", 13/16", 7/8", 15/16", 1", 1-1/16", 1-1/8", 1-1/4"		
OPENING	LENGTH	MAGNET	WALL THICKNESS	SIZE
⊙ 6 Point	Standard	None	Standard	SAE



PART NUMBER	PIECE COUNT	SIZES		
336SA14	14	3/8", 7/16", 1/2", 9/16", 5/8", 11/16", 3/4", 13/16", 7/8", 15/16", 1", 1-1/16", 1-1/8", 1-1/4"		
OPENING	LENGTH	MAGNET	WALL THICKNESS	SIZE
⊙ 6 Point	Long	None	Standard	SAE



PART NUMBER	PIECE COUNT	SIZES		
316M11	11	10, 11, 12, 13, 14, 15, 16, 17, 18, 19, 21		
OPENING	LENGTH	MAGNET	WALL THICKNESS	SIZE
⊙ 6 Point	Standard	None	Standard	Metric



PART NUMBER	PIECE COUNT	SIZES		
336M11	11	10, 11, 12, 13, 14, 15, 16, 17, 18, 19, 21		
OPENING	LENGTH	MAGNET	WALL THICKNESS	SIZE
⊙ 6 Point	Long	None	Standard	Metric



PART NUMBER	PIECE COUNT	SIZES		
M316M11	11	10, 11, 12, 13, 14, 15, 16, 17, 18, 19, 21		
OPENING	LENGTH	MAGNET	WALL THICKNESS	SIZE
⊙ 6 Point	Standard	⊙ Fixed	Standard	Metric



PART NUMBER	PIECE COUNT	SIZES		
316M13	13	10, 11, 12, 13, 14, 15, 16, 17, 18, 19, 21, 24, 27		
OPENING	LENGTH	MAGNET	WALL THICKNESS	SIZE
⊙ 6 Point	Standard	None	Standard	Metric



PART NUMBER	PIECE COUNT	SIZES		
336M13	13	10, 11, 12, 13, 14, 15, 16, 17, 18, 19, 21, 24, 27		
OPENING	LENGTH	MAGNET	WALL THICKNESS	SIZE
⊙ 6 Point	Long	None	Standard	Metric



PART NUMBER	PIECE COUNT	SIZES		
3TE7	7	E-8, E-10, E-12, E-14, E-16, E-18, E-20		
OPENING	LENGTH	MAGNET	WALL THICKNESS	SIZE
⊙ TORX®	Standard	None	Standard	TORX®



1/2"

IMPACT SOCKET SETS

SCREWDRIVERS



- All screwdrivers are made from S2 modified steel for industry leading performance
- Screwdriver blades are through-hardened for maximum durability
- Ergonomic handles are molded on for a permanent bond
- Variety of screwdriver types available for professional users including standard fixed blade, multi-bit, precision and acetate handle drivers

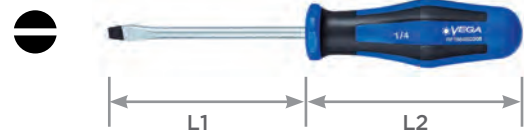
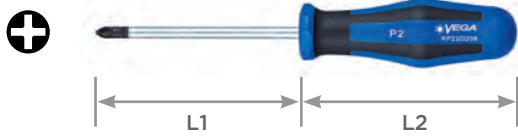

PHILLIPS SCREWDRIVERS

PART NUMBER	TIP SIZE	L1	L2
RP0SD130	#0	2-3/8"	3"
RP1SD79	#1	1"	2-1/8"
RP1SD178	#1	3-1/8"	3-7/8"
RP2SD79	#2	1"	2-1/8"
RP2SD208	#2	4"	4-1/4"
RP3SD268	#3	6"	4-5/8"
RP4SD318	#4	8"	4-5/8"

SLOTTED SCREWDRIVERS

PART NUMBER	TIP SIZE	L1	L2
RF1664SD79	1/4"	1"	2-1/8"
RF1664SD208	1/4"	4"	4-1/4"
RF1664SD258	1/4"	6"	4-1/4"
RF2064SD293	5/16"	7"	4-5/8"
RF2464SD318	3/8"	8"	4-5/8"

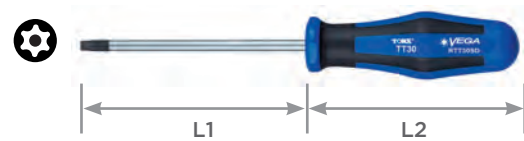
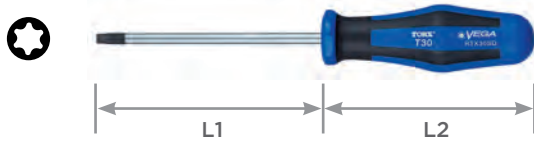

TORX® SCREWDRIVERS

PART NUMBER	TIP SIZE	L1	L2
RTX5SD	5	2-3/8"	3"
RTX6SD	6	2-3/8"	3"
RTX7SD	7	2-3/8"	3"
RTX8SD	8	2-3/8"	3"
RTX9SD	9	2-3/8"	3"
RTX10SD	10	3-1/8"	3-7/8"
RTX15SD	15	3-1/8"	3-7/8"
RTX20SD	20	4"	4-1/4"
RTX25SD	25	4"	4-1/4"
RTX27SD	27	4-1/2"	4-1/4"
RTX30SD	30	4-1/2"	4-1/4"
RTX40SD	40	5-1/8"	4-5/8"
RTX45SD	45	5-1/8"	4-5/8"

TORX® TAMPER SCREWDRIVERS

PART NUMBER	TIP SIZE	L1	L2
RTT5SD	5	2-3/8"	3"
RTT6SD	6	2-3/8"	3"
RTT7SD	7	2-3/8"	3"
RTT8SD	8	2-3/8"	3"
RTT9SD	9	2-3/8"	3"
RTT10SD	10	3-1/8"	3-7/8"
RTT15SD	15	3-1/8"	3-7/8"
RTT20SD	20	4"	4-1/4"
RTT25SD	25	4"	4-1/4"
RTT27SD	27	4-1/2"	4-1/4"
RTT30SD	30	4-1/2"	4-1/4"
RTT40SD	40	5-1/8"	4-5/8"
RTT45SD	45	5-1/8"	4-5/8"



PHILLIPS / SLOTTED SCREWDRIVER SET		TORX® SCREWDRIVER SET		TORX® TAMPER SCREWDRIVER SET	
6 PC SET		6 PC SET		6 PC SET	
PART NUMBER	TIP SIZE	PART NUMBER	TIP SIZE	PART NUMBER	TIP SIZE
R6PF	0	R06TX	10	R06TT	10
	1		15		15
	2		20		20
	3		25		25
	1/4"		30		30
	5/16"		40		40

TORX® is a registered trademark of Acument Global Technologies, LLC.

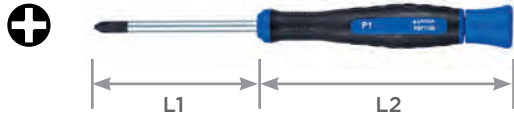

PHILLIPS PRECISION SCREWDRIVERS

PART NUMBER	TIP SIZE	L1	L2
PSP00130	#00	1-9/16"	3-1/2"
PSP0140	#0	2"	3-1/2"
PSP1150	#1	2-3/8"	3-1/2"



TORX® PRECISION SCREWDRIVERS

PART NUMBER	TIP SIZE	L1	L2
PSTX5130	5	1-9/16"	3-1/2"
PSTX6130	6	1-9/16"	3-1/2"
PSTX7130	7	1-9/16"	3-1/2"
PSTX8130	8	1-9/16"	3-1/2"
PSTX9140	9	2"	3-1/2"
PSTX10150	10	2-3/8"	3-1/2"

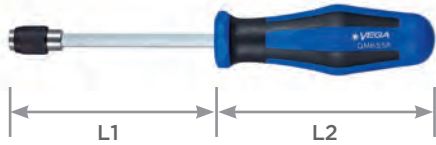

QUICK RELEASE MULTI-BIT SCREWDRIVERS

PART NUMBER	L1	L2
QMBS58	3-1/4"	4-1/4"



6-IN-1 MULTI-BIT SCREWDRIVERS

PART NUMBER	SIZES
VCE6-1	Phillips #1 + #2
	Slotted 3/16" + 1/4"
	Nutdriver 1/4" + 5/16"

See page 84 for countertop display



MAGNETIC BIT RATCHETS

PART NUMBER	OPENING SIZE	LENGTH
NEW! BR90	1/4" Hex	3-1/2"
NEW! BR150	1/4" Hex	6"



SLOTTED PRECISION SCREWDRIVERS

PART NUMBER	TIP SIZE	L1	L2
PSSL12130	1.2mm	40mm	90mm
PSSL15130	1.5mm	40mm	90mm
PSSL20130	2mm	40mm	90mm
PSSL25140	2.5mm	50mm	90mm
PSSL30150	3mm	60mm	90mm
PSSL35150	3.5mm	60mm	90mm
PSSL40150	4mm	60mm	90mm

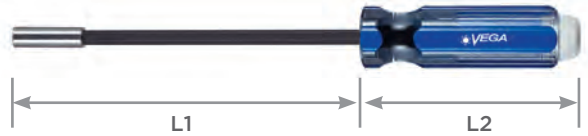

MAGNETIC MULTI-BIT SCREWDRIVERS

PART NUMBER	SIZES	L1	L2
MBS75		3-1/4"	4-1/4"
NEW! MBS75-4	P1, P2, Flat 3-4, Flat 5-6	3-1/4"	4-1/4"
MBS11		6-3/4"	4-1/4"
NEW! MBS11-4	P1, P2, Flat 3-4, Flat 5-6	6-3/4"	4-1/4"

Features removable endcap for bit storage.



4-IN-1 POCKET SCREWDRIVERS

PART NUMBER	SIZES
4PSPP	P1 + P2 Slotted 2mm + 3mm
4PSPP-1	P1 + P2 Slotted 5/32" + 1/8"
4TPP	Torx 5 + 6, Torx 7 + 8

See page 84 for countertop display



CLOSE QUARTERS MINI BIT RATCHET

PART NUMBER	OPENING SIZE	LENGTH
NEW! SBW90	1/4" Hex	3-1/2"



MAGNETIC STUBBY BIT RATCHET

PART NUMBER	OPENING SIZE	LENGTH
NEW! SBR90	1/4" Hex	3-1/2"

TORX® is a registered trademark of Acument Global Technologies, LLC.



- All T-Handles are made from S2 modified steel for industry leading performance and durability
- T-Handles feature two drive ends for maximum versatility
- All drive tips are CNC machined for precise fit in the fastener recess
- Through-hardened for maximum durability
- Ergonomic handles are molded on for a permanent bond

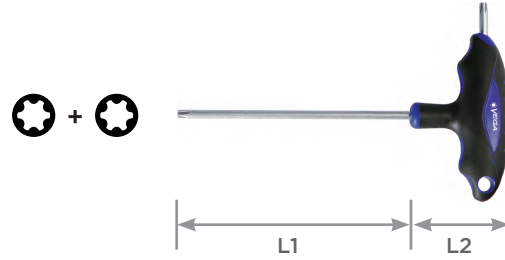
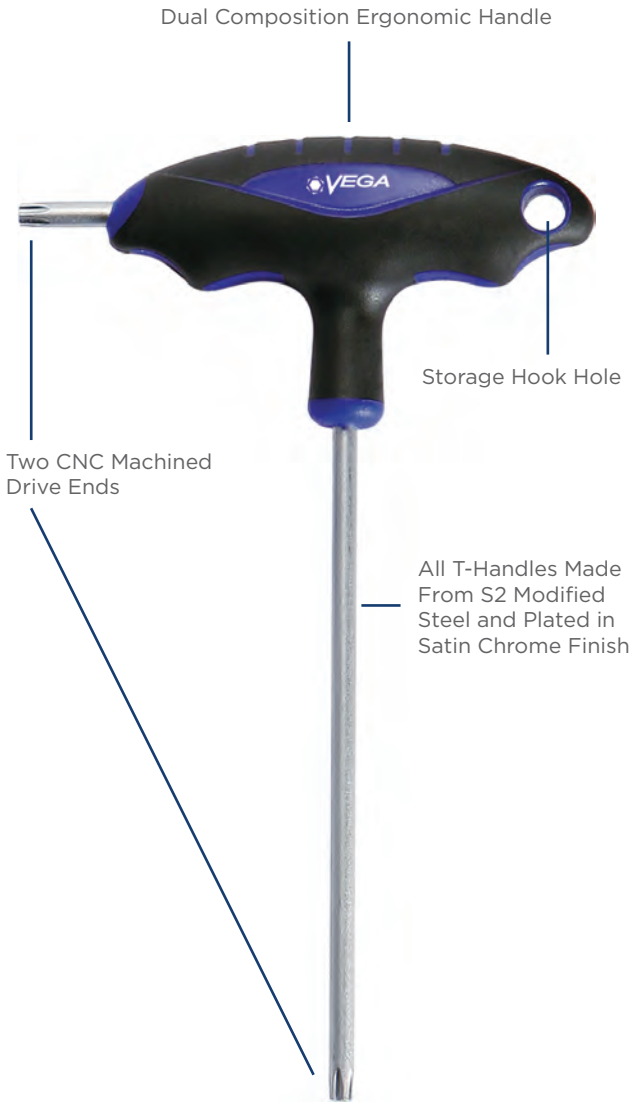

TORX® T-HANDLES

PART NUMBER	TIP SIZE	L1	L2
LTX104	10	4"	1-3/4"
LTX154	15	4"	1-3/4"
LTX204	20	4"	1-3/4"
LTX256	25	6"	2"
LTX276	27	6"	2"
LTX308	30	8"	2"
LTX408	40	8"	2"

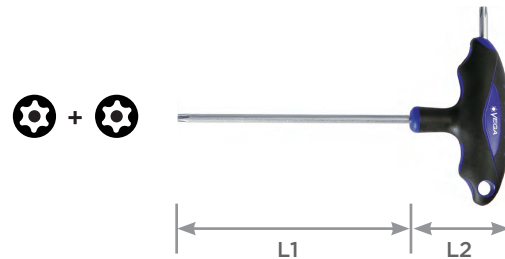

TORX® TAMPER T-HANDLES

PART NUMBER	TIP SIZE	L1	L2
LTT104	10	4"	1-3/4"
LTT154	15	4"	1-3/4"
LTT204	20	4"	1-3/4"
LTT256	25	6"	2"
LTT276	27	6"	2"
LTT308	30	8"	2"
LTT408	40	8"	2"



NEW! TORX® T-HANDLE SETS - 7 PC

PART NUMBER	SIZES
LTX7	10, 15, 20, 25, 27, 30, 40

TORX® is a registered trademark of Acument Global Technologies, LLC.

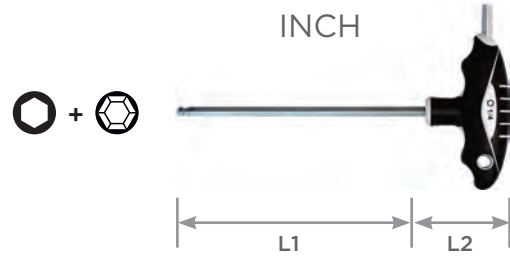
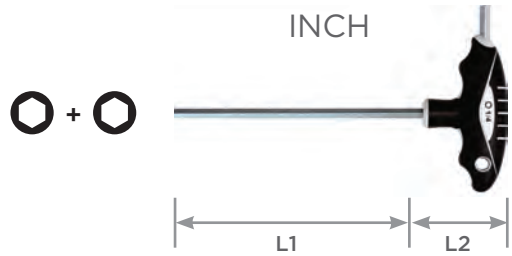

HEX T-HANDLES			
PART NUMBER	TIP SIZE	L1	L2
LTH3324	3/32"	4"	1-3/4"
LTH7644	7/64"	4"	1-3/4"
LTH1804	1/8"	4"	1-3/4"
LTH9644	9/64"	4"	1-3/4"
LTH5326	5/32"	6"	2"
LTH3166	3/16"	6"	2"
LTH7326	7/32"	6"	2"
LTH1406	1/4"	6"	2"
LTH5168	5/16"	8"	2-1/2"
LTH3808	3/8"	8"	2-1/2"

HEX BALL T-HANDLES			
PART NUMBER	TIP SIZE	L1	L2
LTB3324	3/32"	4"	1-3/4"
LTB7644	7/64"	4"	1-3/4"
LTB1804	1/8"	4"	1-3/4"
LTB9644	9/64"	4"	1-3/4"
LTB5326	5/32"	6"	2"
LTB3166	3/16"	6"	2"
LTB7326	7/32"	6"	2"
LTB1406	1/4"	6"	2"
LTB5168	5/16"	8"	2-1/2"
LTB3808	3/8"	8"	2-1/2"

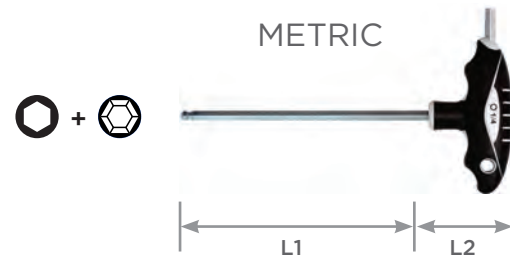
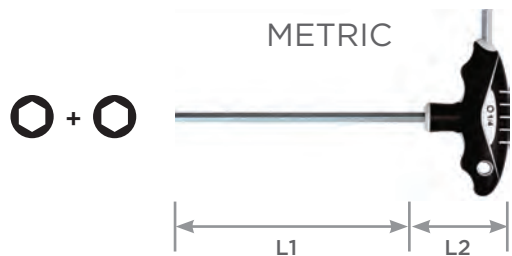

HEX T-HANDLES			
PART NUMBER	TIP SIZE	L1	L2
LTH0204	2mm	100mm	45mm
LTH0254	2.5mm	100mm	45mm
LTH0304	3mm	100mm	45mm
LTH0406	4mm	100mm	45mm
LTH0506	5mm	150mm	51mm
LTH0606	6mm	150mm	51mm
LTH0808	8mm	200mm	61mm
LTH1008	10mm	200mm	61mm

HEX BALL T-HANDLES			
PART NUMBER	TIP SIZE	L1	L2
LTB0204	2mm	100mm	45mm
LTB0254	2.5mm	100mm	45mm
LTB0304	3mm	100mm	45mm
LTB0406	4mm	100mm	45mm
LTB0506	5mm	150mm	51mm
LTB0606	6mm	150mm	51mm
LTB0808	8mm	200mm	61mm
LTB1008	10mm	200mm	61mm



NEW! HEX T-HANDLE SETS - 8 PC

PART NUMBER	SIZES
LTH8	1/8", 9/64", 5/32", 3/16", 7/32", 1/4", 5/16", 3/8"
LTH8M	2mm, 2.5mm, 3mm, 4mm, 5mm, 6mm, 8mm, 10mm

NEW! HEX BALL T-HANDLE SETS - 8 PC

PART NUMBER	SIZES
LTB8	1/8", 9/64", 5/32", 3/16", 7/32", 1/4", 5/16", 3/8"
LTB8M	2mm, 2.5mm, 3mm, 4mm, 5mm, 6mm, 8mm, 10mm

HEX | HEX BALL T-HANDLES

L-KEYS



- All L-Keys are uniquely made from S2 modified steel for industry leading performance
- We stock a broad offering of length, size and tip configuration options
- All drive tips are CNC machined for precise fit in the fastener recess
- Through-hardened for maximum durability



HEX L-KEY SETS

HL10A

Long Length - Inch

Contents:

1/16", 5/64", 3/32", 1/8",
5/32", 3/16", 7/32", 1/4",
5/16", 3/8"



HEX BALL L-KEY SETS

HBL10A

Long Length - Inch

Contents:

1/16", 5/64", 3/32", 1/8",
5/32", 3/16", 7/32", 1/4",
5/16", 3/8"



TORX® L-KEY SETS

TL10A

Long Length

Contents:

8, 10, 15, 20, 25, 27,
30, 40, 45, 50

HL10AM

Long Length - Metric

Contents:

1.5mm, 2mm, 2.5mm,
3mm, 4mm, 5mm,
5.5mm, 6mm, 8mm,
10mm

HBL10AM

Long Length - Metric

Contents:

1.5mm, 2mm, 2.5mm,
3mm, 4mm, 5mm,
5.5mm, 6mm, 8mm,
10mm



TORX® TAMPER L-KEYS

Short Length

PART NUMBER	TIP SIZE	ØD	L1 x L2
LT06S	6	3mm	.50" x 1.65"
LT07S	7	3mm	.55" x 1.75"
LT08S	8	3mm	.60" x 1.85"
LT09S	9	3mm	.65" x 2.00"
LT10S	10	3mm	.70" x 2.10"
LT15S	15	4mm	.75" x 2.20"
LT20S	20	4mm	.80" x 2.35"
LT25S	25	5mm	.85" x 2.50"
LT27S	27	6mm	.95" x 2.75"
LT30S	30	6mm	1.05" x 3.00"
LT40S	40	7mm	1.10" x 3.25"
LT45S	45	8mm	1.25" x 3.75"
LT50S	50	9.1mm	1.35" x 4.25"
LT55S	55	11.3mm	1.50" x 4.75"



CNC Machined Tips



TORX® L-KEYS

Short Length

PART NUMBER	TIP SIZE	ØD	L1 x L2
LT06S	6	3mm	.50" x 1.65"
LT07S	7	3mm	.55" x 1.75"
LT08S	8	3mm	.60" x 1.85"
LT09S	9	3mm	.65" x 2.00"
LT10S	10	3mm	.70" x 2.10"
LT15S	15	4mm	.75" x 2.20"
LT20S	20	4mm	.80" x 2.35"
LT25S	25	5mm	.85" x 2.50"
LT27S	27	6mm	.95" x 2.75"
LT30S	30	6mm	1.05" x 3.00"
LT40S	40	7mm	1.10" x 3.25"
LT45S	45	8mm	1.25" x 3.75"
LT50S	50	9.1mm	1.35" x 4.25"
LT55S	55	11.3mm	1.50" x 4.75"

NEW! *Long Length*

PART NUMBER	TIP SIZE	ØD	L1 x L2
LT08L	8	3mm	.60" x 3.15"
LT10L	10	3mm	.70" x 3.40"
LT15L	15	4mm	.70" x 3.55"
LT20L	20	4mm	.75" x 3.75"
LT25L	25	5mm	.80" x 3.95"
LT27L	27	6mm	.85" x 3.15"
LT30L	30	6mm	.95" x 4.50"
LT40L	40	7mm	1.05" x 4.90"
LT45L	45	8mm	1.15" x 5.25"
LT50L	50	9.1mm	1.25" x 6.00"
LT55L	55	11.3mm	1.35" x 6.75"

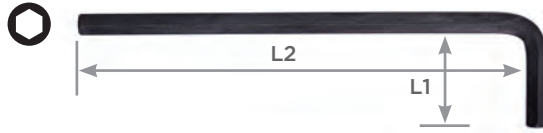

HEX L-KEYS

Short Length - Inch

PART NUMBER	TIP SIZE	L1 x L2
H0120S	1/20"	.50" x 1.65"
H0464S	1/16"	.55" x 1.75"
H0564S	5/64"	.60" x 1.85"
H0664S	3/32"	.65" x 2.00"
H0764S	7/64"	.70" x 2.10"
H0864S	1/8"	.75" x 2.20"
H0964S	9/64"	.80" x 2.35"
H1064S	5/32"	.85" x 2.50"
H1264S	3/16"	.95" x 2.75"
H1464S	7/32"	1.05" x 3.00"
H1664S	1/4"	1.10" x 3.25"
H2064S	5/16"	1.25" x 3.75"
H2464S	3/8"	1.35" x 4.25"
H2864S	7/16"	1.50" x 4.75"

Long Length - Inch

PART NUMBER	TIP SIZE	L1 x L2
H0120L	1/20"	.50" x 2.85"
H0464L	1/16"	.55" x 3.00"
H0564L	5/64"	.60" x 3.20"
H0664L	3/32"	.65" x 3.35"
H0764L	7/64"	.70" x 3.55"
H0864L	1/8"	.75" x 3.75"
H0964L	9/64"	.80" x 3.90"
H1064L	5/32"	.85" x 4.10"
H1264L	3/16"	.95" x 4.50"
H1464L	7/32"	1.05" x 4.90"
H1664L	1/4"	1.10" x 5.25"
H2064L	5/16"	1.25" x 6.00"
H2464L	3/8"	1.35" x 6.75"
H2864L	7/16"	1.50" x 7.50"

Long Length - Metric

PART NUMBER	TIP SIZE	L1 x L2
H015L	1.5mm	14mm x 77mm
H020L	2mm	16mm x 82mm
H025L	2.5mm	18mm x 88mm
H030L	3mm	20mm x 98mm
H040L	4mm	24mm x 104mm
H050L	5mm	28mm x 116mm
H055L	5.5mm	29mm x 127mm
H060L	6mm	30mm x 138mm
H070L	7mm	34mm x 148mm
H080L	8mm	36mm x 158mm
H100L	10mm	40mm x 168mm

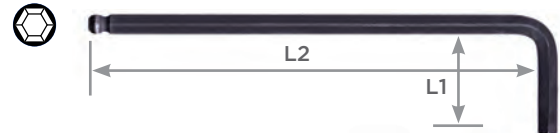

HEX BALL L-KEYS

Long Length - Inch

PART NUMBER	TIP SIZE	L1 x L2
HB0120L	1/20"	.50" x 2.85"
HB0464L	1/16"	.55" x 3.00"
HB0564L	5/64"	.60" x 3.20"
HB0664L	3/32"	.65" x 3.35"
HB0764L	7/64"	.70" x 3.55"
HB0864L	1/8"	.75" x 3.75"
HB0964L	9/64"	.80" x 3.90"
HB1064L	5/32"	.85" x 4.10"
HB1264L	3/16"	.95" x 4.50"
HB1464L	7/32"	1.05" x 4.90"
HB1664L	1/4"	1.10" x 5.25"
HB2064L	5/16"	1.25" x 6.00"
HB2464L	3/8"	1.35" x 6.75"
HB2864L	7/16"	1.50" x 7.50"

Long Length - Metric

PART NUMBER	TIP SIZE	L1 x L2
HB015L	1.5mm	14mm x 77mm
HB020L	2mm	16mm x 82mm
HB025L	2.5mm	18mm x 88mm
HB030L	3mm	20mm x 98mm
HB040L	4mm	24mm x 104mm
HB050L	5mm	28mm x 116mm
HB055L	5.5mm	29mm x 127mm
HB060L	6mm	32mm x 138mm
HB070L	7mm	34mm x 148mm
HB080L	8mm	36mm x 158mm
HB100L	10mm	40mm x 168mm



NEW! HEX TAMPER L-KEYS

Short Length - Inch

PART NUMBER	TIP SIZE	L1 x L2
HT0664S	3/32"	.65" x 2.00"
HT0764S	7/64"	.70" x 2.10"
HT0864S	1/8"	.75" x 2.20"
HT0964S	9/64"	.80" x 2.35"
HT1064S	5/32"	.85" x 2.50"
HT1264S	3/16"	.95" x 2.75"
HT1464S	7/32"	1.05" x 3.00"
HT1664S	1/4"	1.10" x 3.25"
HT2064S	5/16"	1.25" x 3.75"
HT2464S	3/8"	1.35" x 4.25"

HEX | HEX TAMPER | HEX BALL L-KEYS



- All flag driver blades are made from S2 modified steel for industry leading performance and durability
- Flag drivers feature top spinner knobs for easy control and smooth turning
- Flag shaped handles are molded on for a permanent bond
- All drive tips are CNC machined for precise fit in the fastener recess
- Through hardened for maximum durability



TORX® FLAG DRIVERS

PART NUMBER	TIP SIZE	L1	L2	ØD
FDT06S	6	35mm	20mm	2.5mm
FDT07S	7	35mm	20mm	2.5mm
FDT08S	8	35mm	20mm	2.5mm
FDT09M	9	40mm	25mm	3.5mm
FDT10M	10	40mm	25mm	3.5mm
FDT15M	15	40mm	25mm	3.5mm
FDT20M	20	40mm	25mm	4.0mm

TORX^{plus}® FLAG DRIVERS

PART NUMBER	TIP SIZE	L1	L2	ØD
FDIP06S	6	35mm	20mm	2.5mm
FDIP07S	7	35mm	20mm	2.5mm
FDIP08S	8	35mm	20mm	2.5mm
FDIP09M	9	40mm	25mm	3.5mm
FDIP10M	10	40mm	25mm	3.5mm
FDIP15M	15	40mm	25mm	3.5mm
FDIP20M	20	40mm	25mm	4.0mm



TORX® FLAG DRIVER SET

PART NUMBER	TIP SIZE	L1	L2	ØD
FDT7	6	35mm	20mm	2.5mm
	7	35mm	20mm	2.5mm
	8	35mm	20mm	2.5mm
	9	40mm	25mm	3.5mm
	10	40mm	25mm	3.5mm
	15	40mm	25mm	3.5mm
	20	40mm	25mm	4.0mm

TORX^{plus}® FLAG DRIVER SET

PART NUMBER	TIP SIZE	L1	L2	ØD
FDIP7	6	35mm	20mm	2.5mm
	7	35mm	20mm	2.5mm
	8	35mm	20mm	2.5mm
	9	40mm	25mm	3.5mm
	10	40mm	25mm	3.5mm
	15	40mm	25mm	3.5mm
	20	40mm	25mm	4.0mm

FLAG DRIVERS | FLAG DRIVER SETS

TORX® and TORX^{plus}® are registered trademarks of Acument Global Technologies, LLC.



MERCHANDISING SOLUTIONS

- Full range of merchandising options available for varying distributor needs
- Several solutions for showrooms and counters to drive incremental sales opportunities
- Secure locking displays to minimize shrinkage
- Displays can be customized to meet specific market needs

NEW! IMPACTTECH™ BIT-PAK DISPLAYS

PART NUMBER	DESCRIPTION	PIECE COUNT	CASE QTY
P125P2A-25PK-12	Phillips #2 Insert Bit x 1"	25	12
P125R2A-25PK-12	Square #2 Insert Bit x 1"	25	12
P150P2A-15PK-12	Phillips #2 Power Bit x 2"	15	12
P150R2A-15PK-12	Square #2 Power Bit x 2"	15	12



NEW! IMPACTTECH™ COUNTERTOP JARS

PART NUMBER	DESCRIPTION	PIECE COUNT
P125P2A-F250	Phillips #2 Insert Bit x 1"	250
P125R2A-F250	Square #2 Insert Bit x 1"	250
P150P2A-F100	Phillips #2 Power Bit x 2"	100
P150R2A-F100	Square #2 Power Bit x 2"	100
P165P2P2B-F100	Phillips #2 Double End Power Bit x 2-9/16"	100
P165R2R2B-F100	Square #2 Double End Power Bit x 2-9/16"	100
P175MH1CD2-F50	Magnetic Bit Holder x 3"	50
P175MH1QD2-F50	Quick Release Magnetic Bit Holder x 3"	50



NEW! VEGA COUNTERTOP JARS

PART NUMBER	DESCRIPTION	PIECE COUNT
125P2A-F500	Phillips #2 Insert Bit x 1"	500
125P2R-F500	Phillips #2 Reduced Insert Bit x 1"	500
150P2A-F250	Phillips #2 Power Bit x 2"	250
125R2A-F500	Square #2 Insert Bit x 1"	500
150R2A-F250	Square #2 Power Bit x 2"	250
175MH1CD2-F50	Magnetic Bit Holder x 3"	50
145MN416-F100	1/4" Magnetic Nutsetter x 1-3/4"	100
145MN516-F100	5/16" Magnetic Nutsetter x 1-3/4"	100
165MN416-F75	1/4" Magnetic Nutsetter x 2-9/16"	75
165MN516-F75	5/16" Magnetic Nutsetter x 2-9/16"	75



COUNTERTOP DISPLAYS

VEGA 6-IN-1 SCREWDRIVER DISPLAY

PART NUMBER	DESCRIPTION	PIECE COUNT	CASE QTY
VCE6-1	6-in-1 Multi-Bit Screwdriver: P1 + P2, Slotted 3/16" + 1/4", Nutdriver 1/4" + 5/16"	1	12



VEGA 4-IN-1 POCKET DRIVER DISPLAYS

PART NUMBER	DESCRIPTION	PIECE COUNT	CASE QTY
4PSPP	Pocket Driver: P0 + P1, Slotted 2mm + 3mm	1	24
4PSPP-1	Pocket Driver: P0 + P1, Slotted 5/32" + 1/8"	1	24
4TPP	Pocket Driver: Torx 5 + 6, Torx 7 + 8	1	24





High visibility headerboard

Clear security cover, hinges up

Location labels

Key lock



UPC codes, descriptions and space for pricing, all in same locations as front bits

Fastener holes for wall mount

Rubber feet to prevent sliding



PART NUMBER	DESCRIPTION	PIECE CT
NEW! PMD-365	IMPACTTECH™ DISPLAY - SINGLE	365
CONTENTS:		
P125P1A	Phillips #1 Insert Bit x 1"	25
P125P2A	Phillips #2 Insert Bit x 1"	50
P125P3A	Phillips #3 Insert Bit x 1"	25
P150P2A	Square #1 Insert Bit x 1"	25
P125R1A	Square #2 Insert Bit x 1"	50
P125R2A	Square #3 Insert Bit x 1"	25
P125R3A	Phillips #2 Power Bit x 2"	25
P150R2A	Square #2 Power Bit x 2"	25
P125T15A	Torx 15 Insert Bit x 1"	25
P125T20A	Torx 20 Insert Bit x 1"	25
P125T25A	Torx 25 Insert Bit x 1"	25
P175MH1CD2	Magnetic Bit Holder x 3"	10
P165MN416	1/4" Magnetic Nutsetter x 2-9/16"	10
P165MN516	5/16" Magnetic Nutsetter x 2-9/16"	10
P165MN616	3/8" Magnetic Nutsetter x 2-9/16"	10

PART NUMBER	DESCRIPTION	PIECE CT
NEW! PMD-490	IMPACTTECH™ DISPLAY - DOUBLE	490
CONTENTS:		
P125P2A	Phillips #2 Insert Bit x 1"	50
P125P3A	Phillips #3 Insert Bit x 1"	25
P150P2A	Phillips #2 Power Bit x 2"	25
P150P3A	Phillips #3 Power Bit x 2"	25
P170P2A	Phillips #2 Power Bit x 2-3/4"	20
P190P2A	Phillips #2 Power Bit x 3-1/2"	20
P1150P2A	Phillips #2 Power Bit x 6"	20
P125R2A	Square #2 Insert Bit x 1"	25
P150R2A	Square #2 Power Bit x 2"	25
P170R2A	Square #2 Power Bit x 2-3/4"	20
P190R2A	Square #2 Power Bit x 3-1/2"	20
P1150R2A	Square #2 Power Bit x 6"	20
P125T15A	Torx 15 Insert Bit x 1"	25
P125T20A	Torx 20 Insert Bit x 1"	25
P125T25A	Torx 25 Insert Bit x 1"	25
P150T15A	Torx 15 Insert Bit x 2"	20
P150T20A	Torx 20 Insert Bit x 2"	20
P150T25A	Torx 25 Insert Bit x 2"	20
P175MH1CD2	Magnetic Bit Holder x 3"	10
P175MH1QD2	Quick Release Magnetic Bit Holder x 3"	10
P165MN416	1/4" Magnetic Nutsetter x 2-9/16"	10
P165MN516	5/16" Magnetic Nutsetter x 2-9/16"	10
P165MN616	3/8" Magnetic Nutsetter x 2-9/16"	10
P175QADB38	3/8" Quick Release Adapter x 3" Ball Type	10



PART NUMBER	DESCRIPTION	PIECE COUNT
NEW! MVDP-1	VEGA STANDARD BIT DISPLAY	330
CONTENTS:		
125P1A	Phillips #1 Insert Bit x 1"	25
125P2A	Phillips #2 Insert Bit x 1"	50
125P3A	Phillips #3 Insert Bit x 1"	25
125R1A	Square #1 Insert Bit x 1"	25
125R2A	Square #2 Insert Bit x 1"	50
125R3A	Square #3 Insert Bit x 1"	25
125T15A	Torx 15 Insert Bit x 1"	25
125T20A	Torx 20 Insert Bit x 1"	25
125T25A	Torx 25 Insert Bit x 1"	25
165MN416	1/4" Mag Nutsetter x 2-9/16"	10
165MN516	5/16" Mag Nutsetter x 2-9/16"	10
165MN616	3/8" Mag Nutsetter x 2-9/16"	10
175MH1CD	Mag Bit Holder w/ C-Ring x 3"	10
175MH1QD	Quick Release Mag Bit Holder x 3"	10
175ADB38	3/8" x 1/4" Adapter w/ Ball Lock x 3"	5

PART NUMBER	DESCRIPTION	PIECE COUNT
NEW! MVDP-4	VEGA GENERAL BIT DISPLAY	360
CONTENTS:		
125P2A	Phillips #2 Insert Bit x 1"	50
125P3A	Phillips #3 Insert Bit x 1"	50
150P2A	Phillips #2 Power Bit x 2"	25
190P2A	Phillips #2 Power Bit x 3-1/2"	10
125P2R	Phillips #2 Reduced Insert Bit x 1"	50
125R2A	Square #2 Insert Bit x 1"	25
150R2A	Square #2 Power Bit x 2"	25
125T15A	Torx 15 Insert Bit x 1"	25
125T20A	Torx 20 Insert Bit x 1"	25
125T25A	Torx 25 Insert Bit x 1"	25
165MN416	1/4" Mag Nutsetter x 2-9/16"	10
165MN516	5/16" Mag Nutsetter x 2-9/16"	10
165MN616	3/8" Mag Nutsetter x 2-9/16"	10
175MH1CD	Mag Bit Holder w/ C-Ring x 3"	10
175MH1QD	Quick Release Mag Bit Holder x 3"	10



PART NUMBER	DESCRIPTION	PIECE COUNT
NEW! MVDP-2	VEGA SECURITY BIT DISPLAY	375
CONTENTS:		
125TT15A	Torx Tamper 15 Insert Bit x 1"	25
125TT20A	Torx Tamper 20 Insert Bit x 1"	25
125TT25A	Torx Tamper 25 Insert Bit x 1"	25
125TT27A	Torx Tamper 27 Insert Bit x 1"	25
125TT30A	Torx Tamper 30 Insert Bit x 1"	25
125SP04A	Spanner #4 Insert Bit x 1"	25
125SP06A	Spanner #6 Insert Bit x 1"	25
125SP08A	Spanner #8 Insert Bit x 1"	25
125SP10A	Spanner #10 Insert Bit x 1"	25
125SP14A	Spanner #14 Insert Bit x 1"	25
125HT1264A	Hex Tamper 3/16" Insert Bit x 1"	25
125HT1464A	Hex Tamper 7/32" Insert Bit x 1"	25
125HT1064A	Hex Tamper 5/32" Insert Bit x 1"	25
125HT0964A	Hex Tamper 9/64" Insert Bit x 1"	25
125HT0864A	Hex Tamper 1/8" Insert Bit x 1"	25

PART NUMBER	DESCRIPTION	PIECE COUNT
NEW! MVDP-3	VEGA POWER BIT DISPLAY	225
CONTENTS:		
150P1A	Phillips #1 Insert Bit x 2"	25
150P2A	Phillips #2 Insert Bit x 2"	25
150P3A	Phillips #3 Power Bit x 2"	25
190P2A	Phillips #2 Power Bit x 3-1/2"	25
1150P2A	Phillips #2 Power Bit x 6"	25
150R2A	Square #2 Power Bit x 2"	25
150R3A	Square #3 Power Bit x 2"	25
190R2A	Square #2 Power Bit x 3-1/2"	25
1150R2A	Square #2 Power Bit x 6"	25

VEGA METAL COUNTERTOP DISPLAYS

COUNTERTOP DISPLAY FEATURES

- Display rotates for maximum space utilization
- Peghooks included with display
- 9" Wide x 17" Tall



FLOOR DISPLAY FEATURES

- Premium display with high visibility headerboard
- Peghooks included with display
- 16" Wide x 67" Tall

PART NUMBER	DESCRIPTION	PIECE CT
NEW! PFD-40	FLOOR PEGBOARD DISPLAY	228
CONTENTS:		
P125P1A-C2	Phillips #1 Insert Bit x 1" 2pk	6
P125P2A-C2	Phillips #2 Insert Bit x 1" 2pk	6
P125P2A-C5	Phillips #2 Insert Bit x 1" 5pk	6
P125P3A-C2	Phillips #3 Insert Bit x 1" 2pk	6
P150P1A-C1	Phillips #1 Power Bit x 2" 1pk	6
P150P2A-C2	Phillips #2 Power Bit x 2" 2pk	6
P150P2A-C5	Phillips #2 Power Bit x 2" 5pk	6
P150P3A-C1	Phillips #3 Power Bit x 2" 1pk	6
P190P2A-C1	Phillips #2 Power Bit x 3-1/2" 1pk	6
P1150P2A-C1	Phillips #2 Power Bit x 6" 1pk	6
P125R1A-C2	Square #1 Insert Bit x 1" 2pk	6
P125R2A-C2	Square #2 Insert Bit x 1" 2pk	6
P125R2A-C5	Square #2 Insert Bit x 1" 5pk	6
P125R3A-C2	Square #3 Insert Bit x 1" 2pk	6
P150R1A-C1	Square #1 Power Bit x 2" 1pk	6
P150R2A-C1	Square #2 Power Bit x 2" 1pk	6
P150R2A-C5	Square #2 Power Bit x 2" 5pk	6
P150R3A-C1	Square #3 Power Bit x 2" 1pk	6
P190R2A-C1	Square #2 Power Bit x 3-1/2" 1pk	6
P1150R2A-C1	Square #2 Power Bit x 6" 1pk	6
P125T25A-C1	Torx 25 Insert Bit x 1" 1pk	6
P150T10A-C1	Torx 10 Power Bit x 2" 1pk	6
P150T15A-C1	Torx 15 Power Bit x 2" 1pk	6
P150T20A-C2	Torx 20 Power Bit x 2" 2pk	6
P150T25A-C2	Torx 25 Power Bit x 2" 2pk	6
P150T27A-C1	Torx 27 Power Bit x 2" 1pk	6
P150T30A-C1	Torx 30 Power Bit x 2" 1pk	6
P175MH1CD2-C1	Magnetic Bit Holder x 3" 1pk	6
P1150MH1CD2-C1	Magnetic Bit Holder x 6" 1pk	6
P175MH1QD2-C1	Quick Release Mag Bit Holder x 3" 1pk	6
P165MN416-C1	1/4" Mag Nutsetter x 2-9/16" 1pk	6
P165MN516-C1	5/16" Mag Nutsetter x 2-9/16" 1pk	6
P165MN616-C1	3/8" Mag Nutsetter x 2-9/16" 1pk	6
P165MN716-C1	7/16" Mag Nutsetter x 2-9/16" 1pk	6
P165MN816-C1	1/2" Mag Nutsetter x 2-9/16" 1pk	6
P165P2P2B-C1	Phillips #2 Double End Power Bit x 2-9/16" 1pk	6
P165R2R2B-C1	Square #2 Double End Power Bit x 2-9/16" 1pk	6
P19-1DB	19pc Impacttech Bit Set	2
P21-1DB	21pc Impacttech Bit Set	2
P34-1DB	34pc Impacttech Bit Set	2

PART NUMBER	DESCRIPTION	PIECE CT
NEW! PRD-16	ROTATING COUNTERTOP DISPLAY	96
CONTENTS:		
P125P1A-C2	Phillips #1 Insert Bit x 1" 2pk	6
P125P2A-C2	Phillips #2 Insert Bit x 1" 2pk	6
P125P2A-C5	Phillips #2 Insert Bit x 1" 5pk	6
P150P2A-C2	Phillips #2 Power Bit x 2" 2pk	6
P150P2A-C5	Phillips #2 Power Bit x 2" 5pk	6
P150P3A-C1	Phillips #3 Power Bit x 2" 1pk	6
P125R1A-C2	Square #1 Insert Bit x 1" 2pk	6
P125R2A-C5	Square #2 Insert Bit x 1" 5pk	6
P150R2A-C5	Square #2 Power Bit x 2" 5pk	6
P150R3A-C1	Square #3 Power Bit x 2" 1pk	6
P150T25A-C2	Torx 25 Power Bit x 2" 2pk	6
P175MH1CD2-C1	Magnetic Bit Holder x 3" 1pk	6
P165MN416-C1	1/4" Mag Nutsetter x 2-9/16" 1pk	6
P165MN516-C1	5/16" Mag Nutsetter x 2-9/16" 1pk	6
P165MN616-C1	3/8" Mag Nutsetter x 2-9/16" 1pk	6
P165MN716-C1	7/16" Mag Nutsetter x 2-9/16" 1pk	6

IMPACTTECH™ PEGBOARD DISPLAYS

Lined area for taking notes, consisting of numerous horizontal lines.

NOTES



CAT0115-1

Vega Industries Inc. 11933 6th St. Rancho Cucamonga, CA 91730
Phone: 888.688.VEGA (8342) • Fax: 909.484.1120 • www.vegaindustries.net